

## Quarterly Report

### In-situ Scour Testing Device

October 1, 2011~December 31, 2011

Extensive experimental and numerical study was carried out after the most feasible concepts were identified from a number of potential ideas obtained in the previous quarter. Considering optimal performance and practicality in the field, the choice of preliminary prototype was based on small size, sufficient mechanical and hydraulics power, capability of producing steady and uniform flow condition, durability, robustness, and cost-efficiency. Two design concepts stood out as most potential candidates. One of the concepts included a channel that supplied water to the level of stream bed and was redirected to a high-speed horizontal flow over the bed to provide desired shear stress for erosion. A second concept involved an impeller-auger action that produced a localized high shear under a small-footprint device.

Computational Fluid Dynamics (CFD) models were produced to reveal the effectiveness and potential problems of either concept. Figure 1 shows the boundary shear distribution of a much simplified prototype. The result shows that the device can produce desirable flow condition that provide adequate bed shear as prescribed. However, a few potential issues were also revealed. The flow separation that can be seen in Figure 1 at the turning corners produces some uncertainty in amplitude and location of maximum bed shear. The inlet design was also found important to maintain a well-controlled uniform scour pattern. Figure 2 shows that if the inlet pipe is small and without any obstruction, a down jet may occur and produce large scour hole outside the test section.

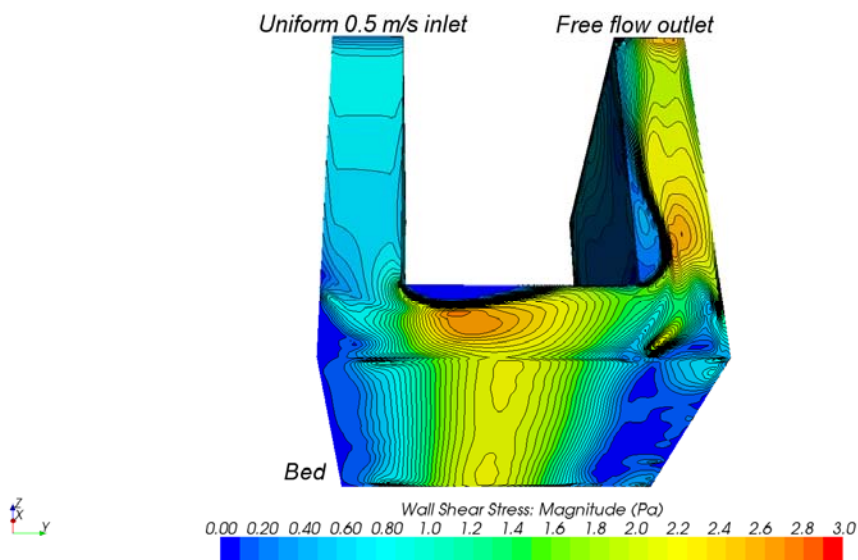
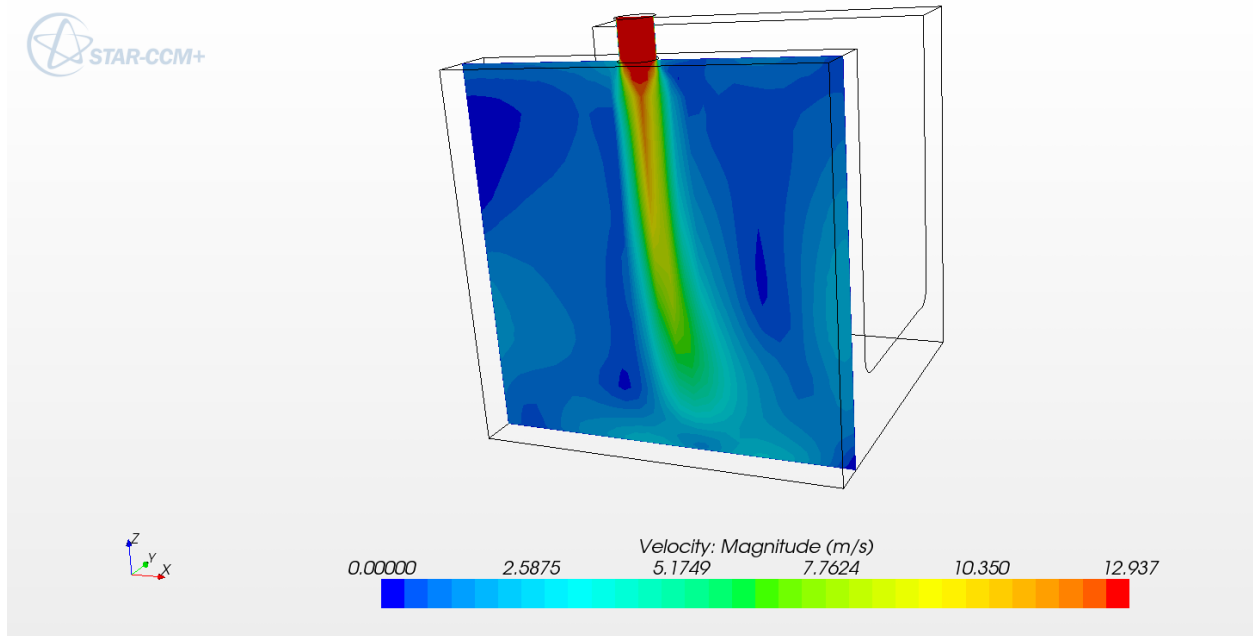


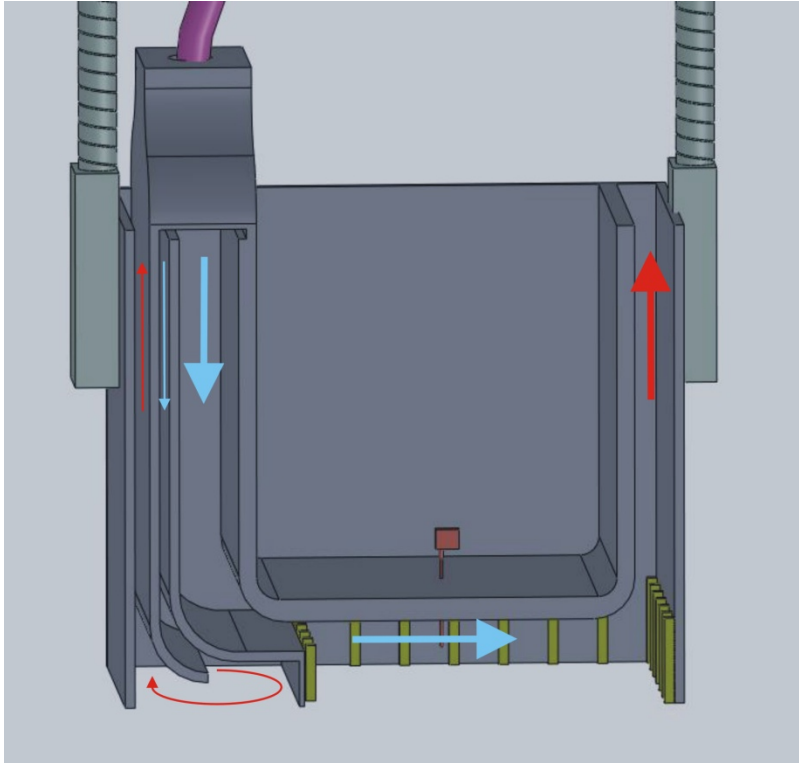
Figure 1 CFD simulation for U-shaped ISTD design



**Figure 2 Uneven velocity/shear distribution caused by improper inlet design**

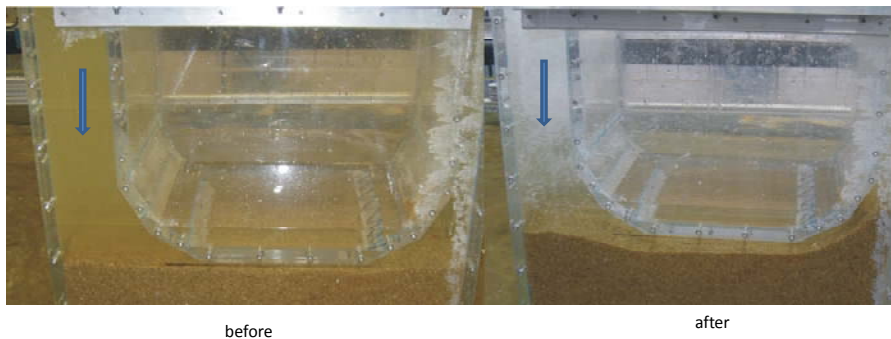
With these observations, it was determined that the initial design would incorporate elliptically smoothed corners and an inlet with either a long, gradual catch or baffles to reduce the direct effect from the inlet. It was also recognized from the CFD simulation that the proportion of the sizes of downward channel, horizontal channel (testing channel), and upward channel (exit) was critical in obtaining proper sediment transport.

Figure 3 shows the result of a design with consideration of all the above issues. The primary part of the supplied water enters the test section from a relatively wide channel, and is redirected to horizontal direction by one or more vanes. The horizontal stream erodes the bed material and creates a lowered bed level inside device. This erosion is measured by a combination of mechanical displacement transducer (potential candidate: LVDT sensors) and electric Resistance Tomography (ERT) is proposed to monitor the scour by measuring the distance between the top wall and the streambed inside the device. When the channel is widened because of the erosion, a pair of screw jacks drives the device deeper into the bed to bring the channel size to the originally set value. This process is repeated so the device gradually sinks into the stream bed. The rate of lowering of the device is an indicator of erosion rate under the preset bed shear created by the internal flow. In Figure 3, a small amount of water is directed into a chamber on the leading (left) side of the device to provide certain level of cutting power outside the testing section so that the device can progress downward without blockage of soil outside the testing section.



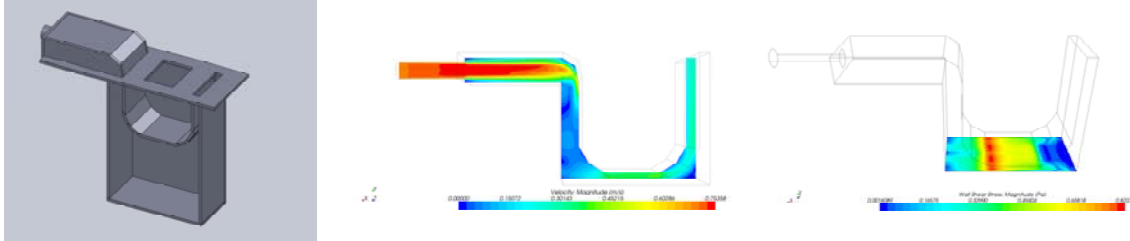
**Figure 3 Preliminary design of U-tube ISTD**

The addition of the secondary channel on the left of Figure 3 adds complexity to the design, but is necessary if turning vanes are used. Otherwise, the vanes may hit the uneroded bed material and prevent the device from lowering. It is conceivable, however, that if the internal channels of the ISTD is proportioned just right, the shear distribution on the bed may produce a shape that provide smooth transition from vertical flow to horizontal flow without the help of vanes. A proof-of-concept device was designed and constructed to verify such possibility of simplified channel design. Figure 4 shows the test device and result. After a period of erosion (photo on the right), the bed forms a well-conditioned curve that gradually direct the flow into and out of the test section.



**Figure 4 Proof-of-concept test of desirable bed erosion with minimal flow-guiding structure**

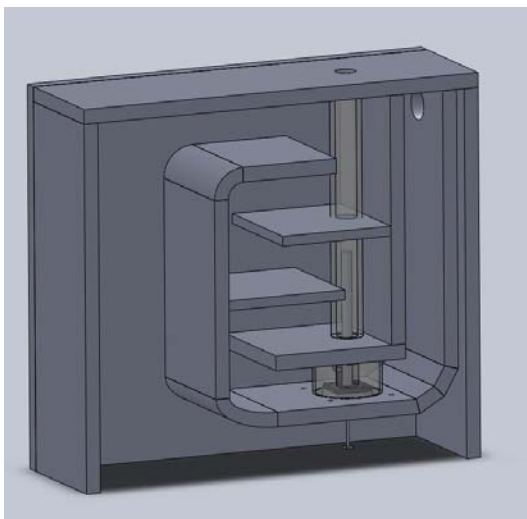
CFD simulation was also carried out to provide validation as well as to assist development of design details. The result of CFD simulation is shown in Figure 5. It indicates that the bed shear is very close to expected distribution. Relatively minor unevenness of flow is observed, indicating further improvement in inlet and channel proportion is desirable.



**Figure 5 CFD Modeling of proof-testing device**

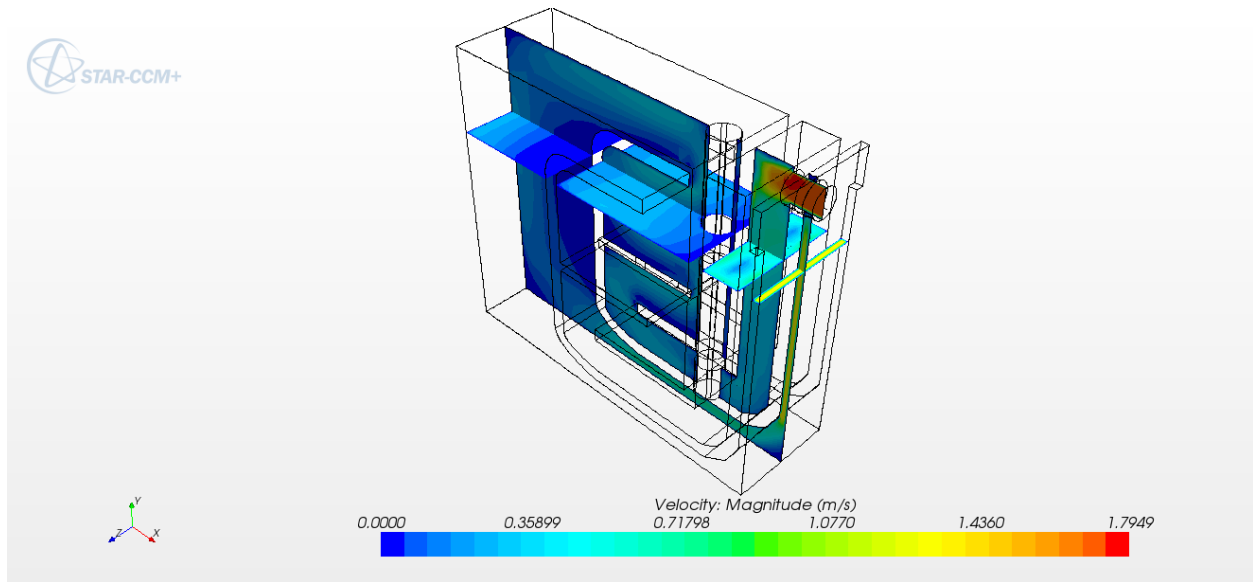
A significant design effort was made to address the issues identified in the pilot modeling. After a few iterations of trial design and thorough scrutiny, a design that combines well-proportioned geometry for flow condition, most compact footprint, and robust instrumentation is produced (Figure 6). Important features include:

1. A long inlet that reduces jet from water supply.
2. Channels of different parts are proportioned so that they:
  - a. Minimize the downward jet that may produce excessive scour before test section.
  - b. High-speed uniform flow at test section that is capable of entrainment of sediment with prescribed particle size and erosion resistance.
  - c. High-speed upward jet that can evacuate heavy particles.

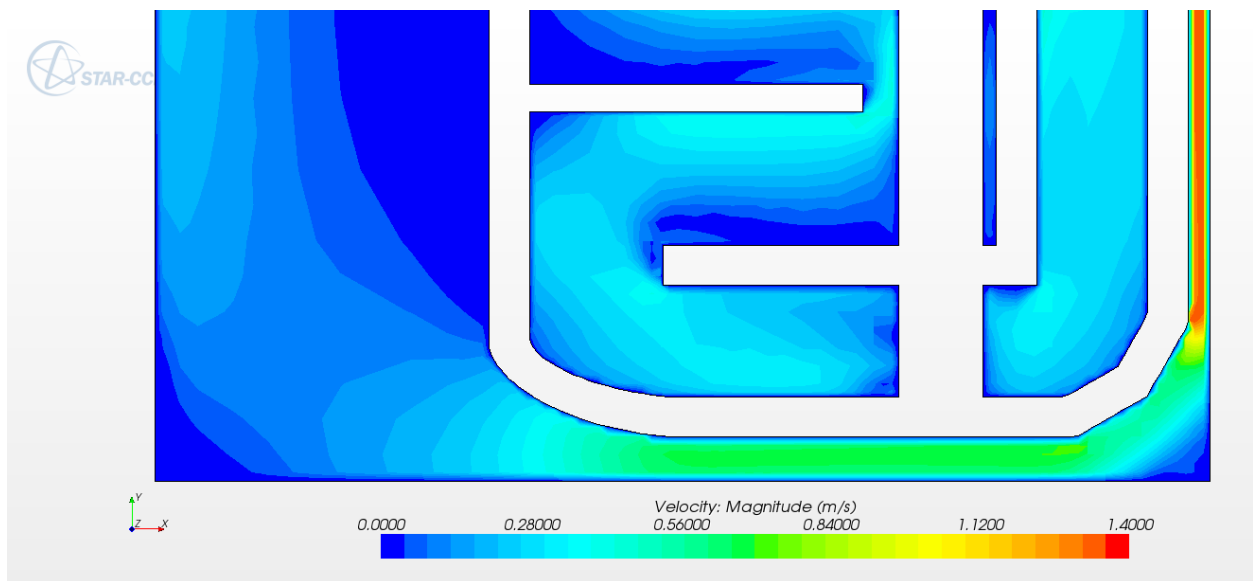


**Figure 6 Final design for demonstrative ISTD unit**

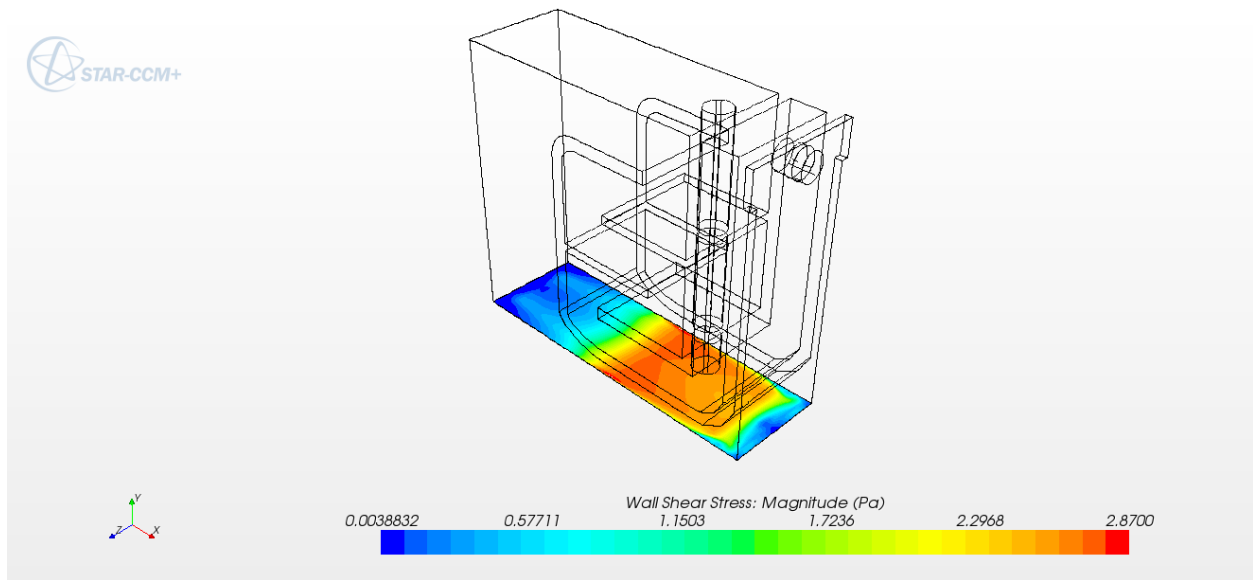
CFD simulations were carried out to verify the performance of the design (see Figure 7). The results verified the expected flow conditions. Figure 8 shows detailed observation near the test section before scour. Figure 9 shows the bed shear before scour. It reveals that the erosion potential is highest inside the test section. This indicates that a preferred bowl-shaped scour is likely to form. Figure 10 shows the simulation of flow condition after scour. The erosion potential becomes more uniform throughout the entire footprint of the device, indicating the likelihood of uniform progression in this scour hole pattern.



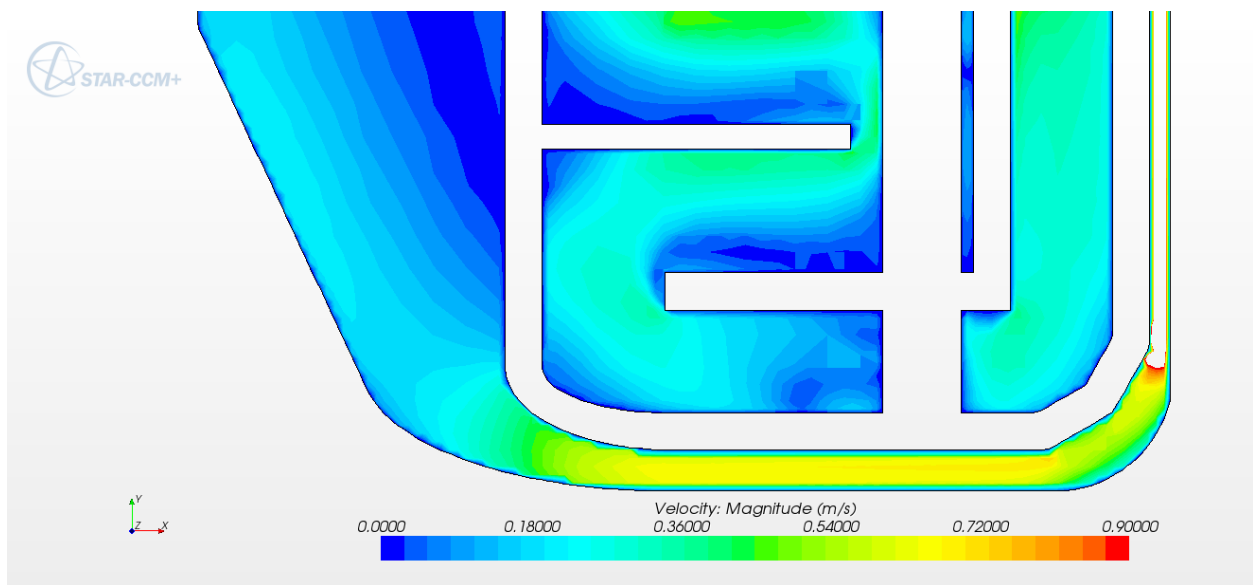
**Figure 7 Velocity in the device from CFD simulation**



**Figure 8 Velocity at test channel before scour**

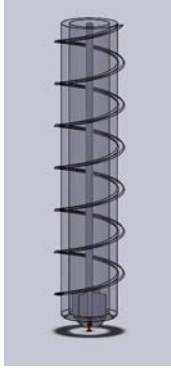


**Figure 9 Bed shear before scour**



**Figure 10 Velocity at test channel after scour**

The second approach of ISTD is a device with a revolving mechanism that generates a localized high shear stress and therefore erodes the streambed. With the erosion power, the device can burrow into the streambed and measure the erosion rate. The advantage of this approach is a much smaller footprint and a compact system with less supporting structure. Figure 11 shows the erosion mechanism of the worm device. The primary shear stress is produced by an impeller mounted at the low point of the device. The eroded bed material is then evacuated by an auger mechanism surrounding the impeller.

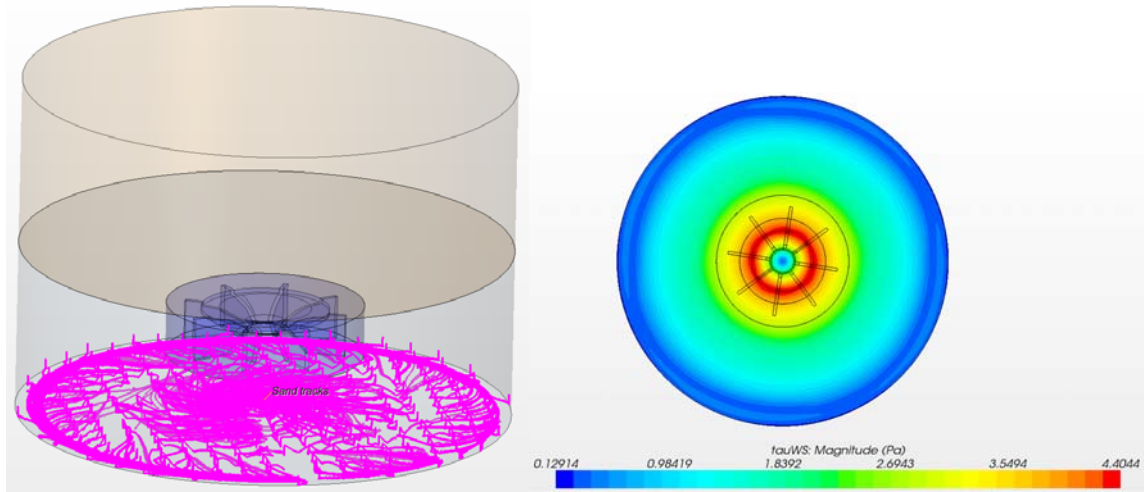


**Figure 11 Erosion mechanism of a Worm Device**

Physical and numerical modeling was conducted to validate the concept and study its effectiveness. Physical test showed that the impeller was capable of producing significant scour in a close range. A few impeller/propellers were compared and the best performer was chosen for further modeling. Figure 12 shows the test setup and results of physical modeling of the worm device. The impeller chosen in this test produced significant scour in a sand box. Figure 13 shows the results from CFD modeling. It demonstrates that the particles below the impeller are brought up slightly by the impeller and concentrate at a certain distance from the edge of the impeller. The bed shear stress is also shown in Figure 13.



**Figure 12 Physical modeling of impeller erosion mechanism**



**Figure 13 Particle movement and bed shear stress caused by the impeller**