

MIDWEST POOLED FUND PROGRAM

Progress Report - Second Quarter 2010 April 1st to June 30th

Midwest Roadside Safety Facility
Nebraska Transportation Center
University of Nebraska-Lincoln

August 2, 2010

Pooled Fund Projects with Bogie or Full-Scale Crash Testing in Past Quarter

Development of a TL-4, Four-Cable, High-Tension, Barrier System for 4:1 V-Ditch Applications – Program Years 12, 14, 18, 19, and 20

In the Second Quarter of 2010, four dynamic bogie tests (test nos. HTCC-3 through HTCC-6) were performed on a short segment of the high-tension cable barrier system in order to evaluate cable release from the soil-embedded, steel line posts using modified U-bolt cable brackets for comparison to the original keyway bracket. Testing was conducted to evaluate the performance of U-bolts fabricated with C1018 and ASTM A449 steel materials. Seven dynamic component tests (test nos. HTCUB-31 through HTCUB-37) were also performed on the modified ASTM 449 U-bolt cable anchor bracket anchored to a rigid jig to determine the cable release capacity in the lateral and vertical directions. Based on the successful component testing program noted above, the final ¼-in. diameter, U-bolt cable brackets will be fabricated from ASTM A449 steel material and held to the posts with a ¼-in. diameter, high-topped, SAE Grade 8 hex nuts.

In the Second Quarter, MwRSF planned to reconstruct the high-tension, four-cable median barrier system in the 4:1 V ditch and 4 ft up the back slope. Then, an 1100C small car re-test was to be performed using the TL-3 safety performance guidelines of MASH. Unfortunately, a significant amount of rain was observed in the Lincoln area during this quarter, thus preventing barrier construction in the bottom of the V-ditch. As a result, the construction and crash testing program has been delayed until the Third Quarter.

Maximum MGS Guardrail Height – Program Year 20

In the Second Quarter of 2010, the 34-in. tall Midwest Guardrail System (MGS) was constructed. On June 29, 2010, one 1100-kg Kia Rio crash test (test no. MGSMRH-1) was performed according to the TL-3 safety performance guidelines of MASH. The small car was successfully contained and redirected.





Based on the results of the successful small car test, the top mounting height of the MGS will be raised to 36 in. and re-tested with the 1100C small car at the TL-3 conditions of MASH. This testing is anticipated in the Third Quarter of 2010.

Impact Evaluation of Free-Cutting Brass Breakaway Couplings – Program Year 20

Following discussions with FHWA and the Illinois Department of Transportation, two low-speed, crushable-nose, pendulum tests were required on various luminaire poles in order to investigate the impact performance of a new, free-cutting, breakaway, brass coupling. The brass coupling is planned for use as replacement to existing, higher-cost couplers.

In 2009, two low-speed pendulum tests were performed. According to the NCHRP Report No. 350 criteria, the maximum allowable change in velocity was exceeded in both pendulum tests. In the First Quarter of 2010, the Illinois DOT modified the design of the brass couplers and requested that MwRSF repeat the pendulum testing on the modified couplers with the existing pole hardware. MwRSF received approval to use contingency funds to cover two additional tests as well as to switch the study to more of an R&D effort.

In the Second Quarter of 2010, two low-speed pendulum tests were performed using modified brass couplers. The first pendulum test (test no. BBC-3) was repeated on a 7-gauge, heavy steel pole with modified brass couplers to evaluate vehicle deceleration and velocity change characteristics for heavy poles. The 50-ft tall steel pole with twin 12-ft mast arms weighed approximately 979 lb. For this test, the low-speed change in velocity was at the limit of 5 m/s, while the high-speed extrapolation for the change in velocity exceeded the ΔV limit. The second pendulum test (test no. BBC-5) was repeated on a weaker, light-weight aluminum pole to evaluate the ability for the brass couplers to break away. A 30-ft tall aluminum pole with a 6-ft mast arm was selected. For this low-speed test, the NCHRP Report No. 350 criteria were met. In addition, the high-speed extrapolation for the change in velocity was met.

The ILDOT deemed it desirable to investigate the impact performance for the currently-used breakaway coupler in combination with the critical heavy steel pole. As such, a third test (test no. BBC-4) was performed using the existing couplers in combination with the tall, heavy steel pole fabricated with 7-gauge steel material. For this low-speed test on the currently-available coupler, the change in velocity was below the limit of 5 m/s. However, the high-speed extrapolation for the change in velocity exceeded the limit. The ILDOT plans to further modify the brass coupler in the Third Quarter and conduct static testing. If promising results are obtained, MwRSF will be contacted to conduct additional pendulum testing.

Pooled Fund Projects with Pending Bogie or Full-Scale Crash Testing

Phase I and II – Guidelines for Post-Socket Foundations for Four-Cable, High-Tension, Barrier Systems – Program Years 19 and 20

Previously, three dynamic component tests were performed on the initial prototype foundation system when placed in a weak soil condition (sand). Concrete fracture was observed in the 5-ft long test specimen, while only concrete cracking of the shaft was observed in the 3-ft long specimen. Following the three tests, design modifications were implemented. A fourth test was performed on the 5-ft long revised concrete specimen placed in a weak soil condition. Due to the rupture of the concrete shaft, the design criteria were re-evaluated and revised. New designs will be prepared in the Third Quarter. Dynamic component testing of new post-socket foundation systems will occur in either the Third or Fourth Quarters.

Testing of End Terminal for Four-Cable, High-Tension Barrier (1100C & 2270P) – Program Years 17 and 20

Previously, this project was delayed in order to complete the crash testing of the high-tension, four-cable barrier system placed in the V-ditch. However, work has begun to be ready for compliance testing in late 2010 or early 2011. The research objective includes the adaptation of a prior low-tension, cable barrier end terminal for use with high-tension cable barrier systems. The end terminal system incorporates a cable release lever technology at each end anchor foundation as well as steel breakaway support posts in the terminal region. In the Second Quarter, the research team began to re-examine prior crash testing of cable barrier end terminals, review existing terminal post configurations, and evaluate the potential for modifying the terminal posts and/or eliminating the breakaway slipbases.

Paper Studies

Cost-Effective Measures for Roadside Design on Low-Volume Roads – Program Year 16

The analysis, evaluation, and documentation of treatment options for culverts, trees, bridges, and slopes/ditches found along low-volume roadways has been completed. A draft report has been prepared and is awaiting internal review.

Submission of Pooled Fund Guardrail Developments to AASHTO TF-13 Hardware Guide

To date, 15 components and 21 systems have been submitted to TF-13 for review and approval, and all have been approved for the Guide over the last 2 years. A small portion of supplemental funding was allocated in the Year 21 Pooled Fund Program.

Cost-Effective Upgrading of Existing Guardrail Systems – Program Year 17

In June 2009, an MwRSF field investigation team conducted a field survey of selected barrier installations throughout the State of Kansas. As part of this one week investigation, more than 60 specific sites were visited, measured, photographed, and documented. A review and compilation of the field survey information was completed in the Fourth Quarter of 2009. An analysis of the field data was initiated in the Fourth Quarter of 2009. Due to a shifting of staff priorities, work was greatly slowed in early 2010. However, analysis of field data will be completed in the Third Quarter of 2010. In the First and Second Quarters, a sensitivity study using RSAP was initiated to decrease the size of the analysis matrix. This analysis is also planned for completion in the Third Quarter.

Safety Performance Evaluation of Vertical and Safety Shaped Concrete Barriers – Program Year 16

An additional 6 years of accident data was collected and tabulated in the Third Quarter of 2009. The narrative and diagram for every additional single-vehicle accident was reviewed, and information extracted from those documents was compiled into the accident database. This information was then merged with additional driver, vehicle, injury, and roadway information that were initially categorized in different files, thus forming one large database. Due to the size of the data set, advanced analysis techniques were required. During the Fourth Quarter, MwRSF personnel garnered access and capability to utilize more advanced statistical software and analysis techniques. The research effort was re-started in the First Quarter of 2010.

In the Second Quarter, the research team requested assistance with the identification of bridge railing type for specific bridge accident sites. To date, information for only a small number of bridges has been obtained and found to be incomplete in many situations. Thus, the research team has inquired into the ability for personnel from each county to photograph selected bridge sites. It is hopeful that this information can be garnered in the Third Quarter.

MGS Implementation – Program Year 18

In 2007, consulting funds were used to assist states with the MGS implementation effort. MwRSF began the effort with a review of CAD details from the Illinois and Washington DOTs. Project correspondence occurred via email with a pre-determined Technical Working group. To date, three subject areas were covered and are as follows: (1) Standard, Half, and Quarter Post Spacing; (2) MGS with Curbs and MGS on 2:1 Slopes; and (3) MGS with Culvert Applications. A fourth category, MGS Stiffness Transition, will be initiated after the simplified, wood-post transition project is completed. The reporting of the simplified, steel-post, approach guardrail transition system attached to the MGS is planned for completion in the Third Quarter of 2010. The MGS implementation effort will commence in the Third Quarter of 2010.

LS-DYNA Modeling Enhancement Funding – Program Year 18

No work was performed on this project during the reporting period.

Projects Funded by Individual State DOTs and Routed Through NDOR and/or Pooled Fund Program

Development of a New, TL-4 Precast Concrete Bridge Railing System (Nebraska Department of Roads)

For this project, a TL-4, aesthetic, open concrete bridge railing was developed for use on cast-in-place decks as well as precast deck panels. Due to many factors, existing project funds were insufficient to complete the construction and crash testing phases of this research study. MwRSF-UNL researchers have sought funds from alternative sources including the NCHRP IDEA program and the 2009 Midwest States Pooled Fund Program. In 2010, MwRSF will seek funding from the FHWA Highways for Life Program.

Universal Breakaway Steel Post for Guardrail (Minnesota DOT)

The final Phase I report, which contained the development and testing of the new breakaway post as well as the results from the first unsuccessful 2000P test, was published in the First Quarter of 2010.

A modified bullnose median barrier system was reconstructed in the Fourth Quarter of 2009. The 2000P re-test was conducted after the completion of the Fourth Quarter Progress Report and not contained therein. On December 21, 2009, the 2000P retest was successfully performed into the three beam bullnose median barrier according to the NCHRP Report No. 350 guidelines. The 2000P vehicle was

safely captured within the barrier system. The Phase II report has been completed. A draft report will be sent to the sponsor in the Third Quarter.

At the April 2010 Annual Meeting of the Midwest States Pooled Fund Program, the member states approved supplemental project funding in the Year 21 program to complete compliance testing of the universal breakaway steel post for use in three beam bullnose applications. Two additional crash tests are planned in order to seek FHWA acceptance under the NCHRP Report No. 350 safety performance guidelines. Barrier construction and crash testing will occur in the Third Quarter.

Awaiting Reporting

Phase I & II Development of a TL-3 MGS Bridge Rail – Program Years 18 and 19

The final research and test report was prepared in the Second Quarter. The report will be published in the Third Quarter.

Development of a Temporary Concrete Barrier Transition – Program Year 16

Comments on the draft report were received from the member states in the First Quarter. These comments will be considered for implementation into the final report in the Third Quarter of 2010.

Standardizing Posts and Hardware for MGS Transition – Program Years 18 and 19

A draft report was prepared for the simplified, steel-post, approach guardrail transition system attached to the MGS. The draft report will be sent to the member states for review and comment in the Third Quarter of 2010. A BARRIER VII computer simulation effort is also underway and nearly completed to evaluate the dynamic barrier performance when using wood posts with both an upper and lower bound for post-soil behavior. An 8-in. x 10-in. wood post has been recommended as a replacement for W6x15 steel posts used in approach guardrail transitions. A second report will contain the results of the wood-post transition system, which is planned for completion in the Third Quarter of 2010.

Midwest Guardrail System Placed at the Breakpoint of a 2:1 Slope – Bogie Testing Project Using Year 14 Contingency Funds

An MGS system utilizing 9-ft long, W6x9 steel posts spaced at 6-ft 3-in. centers was successfully crash tested utilizing a 2270P Dodge Quad Cab vehicle. A draft report was sent to the States in the Fourth Quarter of 2009. A final report was completed in the First Quarter of 2010.

Previously, several member states noted a desire for a wood-post alternative for the MGS placed on a 2:1 slope. As such, a dynamic bogie testing program was conducted in order to determine the appropriate length of a 6-in. x 8-in. wood post for placement at the slope breakpoint of a 2:1 fill slope. A second draft report was initiated in the Fourth Quarter of 2009 which contains the results from the wood-post, component testing program as well as some additional steel post tests for comparison purposes. Work was continued on the draft report for the bogie testing program in the First and Second Quarters of 2010. A draft report has been prepared and is awaiting internal review.

Performance Limits for a 6-in. High, AASHTO Type B Curb Placed in Advance of the MGS – Program Year 17

On November 10, 2009, a 2270P crash test (test no. MGSC-6) was performed at the TL-2 impact conditions on the MGS placed 6 ft behind a 6-in. tall curb with a 37-in. rail height relative to the roadway. During the test, the vehicle was contained and smoothly redirected. The test results were found to meet the TL-2 safety performance criteria provided in MASH. Since inadequate project funding remained within the current project budget to run the 2270P test, existing contingency funds were requested and obtained to complete the data analysis, documentation, and reporting.

In the Second Quarter of 2010, the draft report was completed for the TL-2 crash testing program. The report will be submitted to the member states in the Third Quarter. As previously noted, the research team will provide recommendations pertaining to the safety performance of the 1100C vehicle as well as the potential need for small car crash testing on the TL-2 MGS curb system.

Draft Reports - Pooled Fund

Not Applicable.

Final Reports - Pooled Fund

Not Applicable.

Draft Reports - Individual State DOT and Routed Through NDOR/Pooled Fund

Not Applicable.

Final Reports - Individual State DOT and Routed Through NDOR/Pooled Fund

Not Applicable.

Pooled Fund Consulting Summary

Midwest Roadside Safety Facility
April 2010 – July 2010

This is a brief summary of the consulting problems presented to the Midwest Roadside Safety Facility over the past quarter and the solutions we have proposed.

Problem # 1 – Tie-Down Strap for Temporary Barrier

State Question:

Bob,

I was reviewing MwRSF's detail for the temporary barrier tie-down strap. I have a question about a plate installed near the bottom of the connection pin (see attached drawings).

How is this plate installed? If it is welded to the connection pin, I don't think the connecting pin can be installed. I don't think that the plate can be installed after the tie-down strap and the barriers are installed (not enough room to work).

Looking at Iowa's concrete barrier detail, they don't show the plate on the connection pin.

If the plate is needed what is its' purpose? I don't believe that it is needed for the double shear connection (i.e. the double shear is provided by the second set of loops).

Any information you can provide would be greatly appreciated.

Sincerely,

Erik Emerson P.E.
Standards Development Engineer-Roadside Design
Wisconsin Department of Transportation

MwRSF Response:

Hi Erik,

The plate on the bottom of the connection pin is not welded. It slides onto the bottom of the connection pin and is held in place by the bolt.

In order to install it with the strap tie-down, you have to lift the strap up, put the plate and bolt on the connection pin, and then lower the strap back down. The strap can then be bolted to the drop-in anchors or secured with wedge bolts.

The system was tested with the bolt and plate in place. Because this system relies on loading of the connection pin to restrain the barrier, we believe that the retention plate and bolt are necessary to prevent the pin from pulling out of the loops. I don't believe that the bolt has sufficient capacity to prevent the pullout of the pin under high loads. Thus, the plate is likely necessary.

Thanks

Bob Bielenberg, MSME, EIT
Research Associate Engineer
Midwest Roadside Safety Facility

Problem # 2 – Curved Rail W-beam Transition and Exposed Concrete Edge

State Question:

Ron,

During your move I had asked whether or not you viewed the curved parapet treatment (shown on photos that I sent you) to be crashworthy. You mentioned some research that had been done by TTI, but as you were mid-move, you were unable to put your hands on the data. Have you been able to locate it and do you have an opinion?

Since then, another issue has come up. We are replacing hundreds of bridges around the state in the coming few years, and in an effort to make the undertaking as cost-effective as possible, we have adopted a 350-approved bridge end connection that employs two double-nested w-beams for stiffness at the end. This arrangement bears the federal approval number HMHS-B65 if you wish to view its test summary and drawings. The FHWA approval letter cautions practitioners to taper the parapet wall to the top of the rail to avoid snagging potential.

Unfortunately, we've recently realized that about 30 bridges have been built without the taper (as shown below). In fact, the condition in the field has the parapet height about 2 inches above the rail. The wall does have a 3/4 inch chamfer around its top and sides.

My questions are these. Do you see a snag potential in the as-built condition? If so, is it drastic enough for us to fix it? Grinding the concrete taper is not an option so the only remedy would be to raise the rail: an exercise we don't want to undertake. Of course we will if there is a danger to the public.

I look forward to your answer.

Joe Jones



Figure 1. Curved Rail W-beam Transition

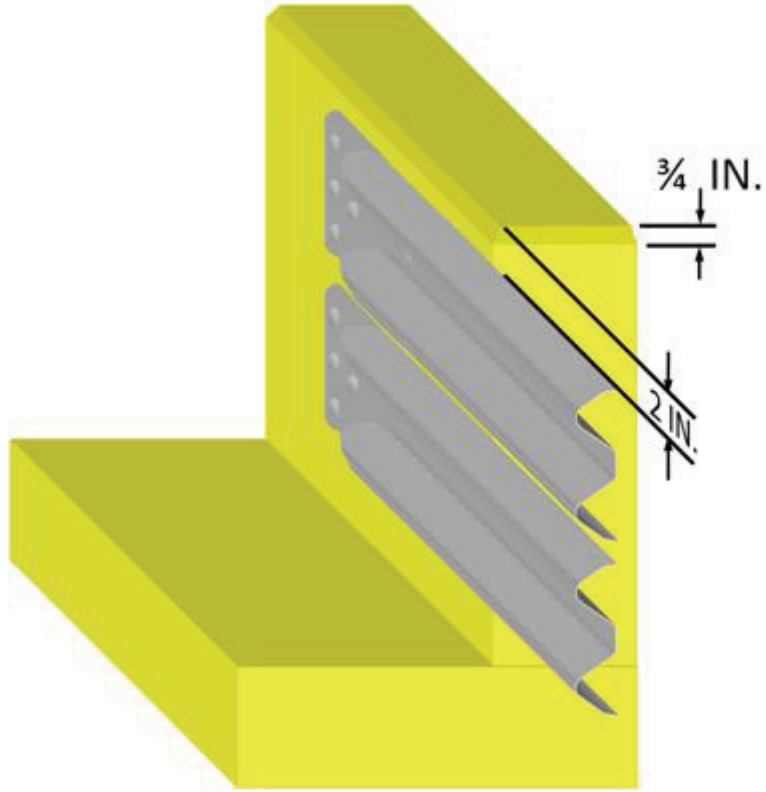

Figure 2. Exposed Concrete Edge

MwRSF Response:

Joe:

I have reviewed a few prior development and crash testing efforts regarding the exposure of concrete buttresses above the rail element in approach guardrail transitions, more specifically two systems that were developed with funding from the Pooled Fund Program.

For the first barrier system, a thrie beam approach guardrail transition was developed and crash tested for use with a half-section New Jersey shape concrete barrier. The thrie beam's top mounting height was 31 in., while the top height of the concrete parapet was 32 in. The top horizontal edge of the concrete parapet's upstream end was not chamfered. As such, there was 1 in. of exposed concrete above the 31-in. tall thrie beam. For this design, the 1-in. of exposed concrete did not result in excessive vehicle snag on the upstream end.

For the second barrier system, a thrie beam approach guardrail transition was developed and crash tested for use with a single-slope concrete median barrier. The thrie beam's top mounting height was 31 in., while the top height of the end concrete parapet was 31 in. but with the concrete surface sloping upward at an 8:1. The top horizontal edge of the concrete parapet's upstream end was not chamfered. As such, there was no exposed concrete above the 31-in. tall thrie beam except for the upper 8:1 sloped surface.

For the approach guardrail transition system shown below, there is approximately 2 in. of exposed concrete above the upper W-beam guardrail. The original crash-tested transition system (link provided below) was configured with the concrete end flush with the top of the W-beam rail, thus mitigating any concerns for the engine hood and front quarter panel to snag on the concrete. Due to the lower W-beam rail height as compared to existing thrie beam transitions and the 2-in. exposed height, it is recommended that the transition system be retrofitted to mitigate the potential for vehicle snag on the upper concrete edge.

http://safety.fhwa.dot.gov/roadway_dept/policy_guide/road_hardware/barriers/pdf/b-65.pdf

MwRSF would be willing to discuss and brainstorm potential options for safely retrofitting the transition system to mitigate the vehicle snag concerns. I look forward to hearing from you in the near future.

Respectfully,

Ron

Ronald K. Faller, Ph.D., P.E.
Research Assistant Professor

Joe,

Here is the research on systems similar to the curved rail system that you asked for any prior research on. Please let me know if you need anything further on this.

Thanks!
Karla

W-Beam Transition to Curved Concrete Bridge Railing Report Comparison

W-Beam Guardrail Transition to a Curved Concrete Parapet

A similar design featuring a W-beam guardrail transition to a curved concrete parapet has been found in Brondstad et al [1]. Two tests, test nos. NC-1 and NC-1M, were conducted at nominal speeds of 60 mph and angles of 25 degrees with 4,500-lb sedans. Summaries of the tests are given below.

Test No. NC-1

This system was configured with eight 6-ft long, W6x15.5 structural steel posts with 12-in. long W6x15.5 steel blockouts. The four posts adjacent to the parapet had a 1 ft - 6³/₄ in. post spacing and the next four were at a 3 ft - 1¹/₂ in. spacing. A wooden blockout was placed between the guardrail and the curved concrete parapet.

The test vehicle, a 1978 Dodge with a gross static weight of 4,642 lb, impacted the transition at a nominal speed of 60 mph and at an angle of 25 degrees. The vehicle was smoothly redirected. However, the left-front wheel pushed up against the parapet, indicating wheel snag on the last post. The system met all safety performance criteria of NCHRP Report No. 230.

Test No. NC-1M

Due to the snagging of the wheel in test NC-1, the system was modified by placing a second section of W-beam guardrail below the first. This single 12-ft 6-in. W-beam rail was bolted to the posts, but not attached to the parapet/wingwall itself. The rail was then field bent behind and attached to the furthest upstream post that it traversed. In this instance, it was the fifth post from the parapet.

The vehicle was smoothly redirected, and the lower section of W-beam significantly reduced the wheel snag observed previously in test no. NC-1. The system met all safety performance criteria of NCHRP Report No. 230.

W-Beam Guardrail to Vertical and Safety-Shape Concrete Parapets

Texas Transportation Institute (TTI) conducted a study of W-beam guardrail to concrete parapet transitions [2]. The system configurations consisted of vertical concrete parapets and safety-shaped concrete parapets where curved sections were cut out of them. At the transition point between the W-beam and the concrete parapet, a 6-in. and an 8-in. diameter, 12-in. long, Schedule 40 galvanized steel spacer tube was used for the vertical concrete parapet and the safety-shape concrete parapet, respectively. The purpose of the spacer was to provide a controlled collapsible spacer between the rail and the parapet.

Test No. 7199-2 (Vertical Concrete Parapet)

For this system, the first three posts adjacent to the concrete parapet were 8-ft long, W8x21 structural steel posts with an embedment depth of 68 in. The next three posts were standard 6-ft long, W6x15 structural steel posts with an embedment depth of 44 in. The six posts were placed at a 3 ft - 1½ in. spacing. The rail element consisted of one 25-ft section of 12-gauge W-beam guard rail mounted at a height of 27 in. Backup plates were located at each post. A 6-in. diameter spacer tube was placed between the rail and the concrete parapet.

The test vehicle, a 1982 Oldsmobile Ninety-Eight with a test inertial mass of 4,500 lb, impacted the transition 6.0 ft upstream from the end of the concrete parapet at 61.4 mph and at an angle of 25.1 degrees. The vehicle was successfully redirected, but a considerable amount of wheel contact with the end of the parapet occurred. The spacer tube performed as designed by collapsing approximately 1 in. in a controlled manner before significant pocketing and snagging occurred. The system met all safety performance criteria of NCHRP Report No. 230. Although deemed acceptable, due to the crash results, it was then desirable to enhance the impact performance by using a nested W-beam rail.

Test No. 7199-3 (Vertical Concrete Parapet)

This system consisted of eight W6x15 structural steel posts with an embedment depth of 44 in. The post spacing between the first five posts adjacent to the concrete parapet was 1 ft – 6¼ in., and the next three posts were at a 3 ft – 1½ in. spacing. The two additional posts were not attached to the rail system and were installed with the face of the blockout adjacent to the back side of the rail. The rail element consisted of nested 12-gauge W-beam rail mounted at a height of 27 in. A 6-in diameter spacer tube was placed between the rail and the concrete parapet

The test vehicle, a 1980 Oldsmobile Ninety-Eight with a test inertial mass of 4,500 lb, impacted the transition 6.0 ft upstream from the end of the concrete parapet at 62.0 mph and at an angle of 24.4 degrees. The vehicle was successfully redirected. However, wheel contact with the end of the flared face of the parapet occurred. The spacer tube collapsed approximately 2½ in. and fulfilled its designed function. The system met all safety performance criteria of NCHRP Report No. 230.

Test No. 7199-5 (Vertical Concrete Parapet)

This system consisted of six 6-ft long, W6x15 structural steel posts with an standard embedment depth of 44 in. and a spacing of 3 ft- 1½ in. The rail element consisted of nested 12-gauge W-beam rail mounted at a height of 27 in. A rub-rail consisting of C6x8.2 steel channel was attached beneath the original W-beam rail, in order to mitigate wheel contact on the concrete parapet. The rub-rail was anchored to the concrete parapet and connected to the front flanges of the steel guardrail posts. The upstream end of the rub-rail was terminated behind the fifth post in the transition. A 6-in. diameter spacer tube was placed between the rail and the concrete parapet.

The test vehicle was a 1984 Cadillac Coupe DeVille with a test inertial mass of 4,500 lb. The test vehicle impacted the transition 6.0 ft upstream from the end of the concrete parapet at 61.0 mph and at an angle of 24.7 degrees. The rub rail effectively prevented wheel snag on the end of the concrete parapet, and the vehicle was successfully redirected. The steel spacer pipe collapsed 1½ in. The system met all safety performance criteria of NCHRP Report No. 230.

Test No. 7199-9 (Safety-Shape Parapet)

This system consisted of three 8-ft long, W8x21 structural steel posts with an embedment depth of 68 in. placed adjacent to the safety-shape concrete parapet at a spacing of 3 ft – 1½ in. The next three posts were 6-ft long, W6x15 structural steel posts with an embedment depth of 44 in. at a spacing of 3 ft – 1½ in. The rail element consisted of nested 12-gauge W-beam rail mounted at a height of 27 in. Because the safety-shape barrier was sloped it was necessary to add a specially made steel spacer block to increase the distance between the W-beam rail and the exposed toe of the concrete barrier. The block was tapered to reduce the potential of wheel snag when impacted from the opposite direction. An 8-in. diameter spacer tube was used between the rail and the flared face of the parapet.

The test vehicle, a 1982 Cadillac Fleetwood Brougham with a test inertial mass of 4,500 lb, impacted the transition 6.0 ft upstream from the end of the concrete parapet at 60.1 mph and at an angle of 25.3 degrees. The dynamic deflection of the rail exceeded predicted amounts, which was potentially attributed to poor soil compaction, and resulted in increased wheel snag on the end of the concrete parapet. The left-front wheel contacted the concrete parapet, causing the motor to be pushed back into the firewall and resulting in a substantial amount of intrusion into the occupant compartment. The 8-in. diameter spacer tube between the nested rail and the flared portion of the concrete parapet collapsed approximately 2¾ in. Due to the significant amount of intrusion into the occupant compartment, this test did not meet all safety performance criteria in NCHRP Report No. 230 and was deemed a failure.

Test No. 7199-10 (Safety-Shape Parapet)

This system consisted of three 8-ft long W8x21 structural steel posts with an embedment depth of 68 in. placed adjacent to the safety-shape concrete parapet and followed by three 6-ft long, W6x15 structural steel posts with an embedment depth of 44 in. All six posts were placed at a 3 ft – 1½ in. spacing. The rail element consisted of a nested 12-gauge W-beam rail mounted at a height of 27 in. Because the safety-shape barrier was sloped it was necessary to add a specially made steel spacer block to increase the distance between the W-beam rail and the exposed toe of the concrete barrier. The block was also tapered to reduce the potential of wheel snag when impacted from the opposite direction. An 8-in diameter spacer tube was used between the rail and the flared face of the parapet. A rub-rail made of C6x8.2 steel channel was placed below the W-beam rail. The rub-rail was blocked out the same distance as the W-beam rail element by extending the W6x15 post blockout an additional 8½ in. to a total length of 22½ in. The end of the rub-rail was anchored to the sloped face of the toe, and the lower flange was tapered to allow further extension onto the safety-shape barrier. In order to maintain a vertical face for the rub-rail, a wooden block, trimmed to match the slope of the toe, was placed behind the rub-rail. In addition, a tapered steel end shoe was used at the end to minimize the potential for wheel snag due to impacts from the opposite direction. The rub-rail was attached to the posts in the same way described in test no. 7199-5.

The test vehicle was a 1983 Oldsmobile Regency with a test inertial mass of 4,500 lb. The test vehicle impacted the transition 6.0 ft upstream from the end of the concrete parapet at 62.7 mph and 26.5 degrees. Although wheel contact with the toe of the parapet occurred, the rub rail significantly reduced the severity of the wheel snag when compared to that observed in test no. 7199-9. The transition performed as intended and successfully redirected the vehicle. The vehicle began to yaw counter-clockwise after exiting the test area. The 8-in. spacer tube between the nested rail section and the concrete parapet collapsed approximately 2 in. The concrete parapet showed signs of cracking near the anchor

bolts and the junction between the sloped face and the toe. The system met all safety performance criteria of NCHRP Report No. 230.

W-Beam Transition to Vertical Flared Back Concrete Bridge Parapet (Test No. 405491-2)

Another system with similarities to the curved concrete parapet with W-beam and crush tube was found; however, this system consisted of concrete barrier that was not curved, but rather flared back away from the traffic side [3]. The traffic face of the vertical flared back concrete parapet transitioned from a safety-shape to a vertical face barrier over a distance of 2,300 mm. The vertical face extended another 750 mm and then flared back away from the traffic side 215 mm over a longitudinal distance of 850 mm. The eight posts adjacent to the concrete barrier were 1,830 mm long, W150x12.6 structural steel posts. The first four were spaced at 476 mm, and the next four posts were at 953 mm. All posts had 150-mm x 200-mm timber blockouts. The rail element consisted of nested 12-gauge W-beam guardrail mounted at a height of 685 mm. A 6-in. diameter steel spacer tube was used between the rail and the flared face of the parapet.

The test vehicle, a 1989 GMC 2500 pickup truck with a test inertial mass of 2000 kg, impacted the transition 150 mm upstream of post 4 at a speed of 99.8 km/h and at an angle of 25.3 degrees. The transition successfully contained and redirected the test vehicle. However the vehicle rolled one revolution counterclockwise, resulting in significant damage that may have caused serious injury to occupants. The vehicle came to rest in adjacent traffic lanes. Due to these occurrences, the system failed to meet all safety performance criteria for NCHRP Report No. 350.

Vertical Flared Back Transition (Test No. 3-21)

Another system with similarities to the curved concrete parapets with a W-beam was found; however, this system consisted of concrete barrier that was not curved, but rather flared back away from the traffic side of the barrier [4-5]. The traffic face of the vertical flared back concrete barrier transitioned from a safety-shape to a vertical face barrier over a distance of 2,300 mm. The vertical face extended another 750 mm and then flared back away from the traffic side 215 mm over a longitudinal distance of 850 mm. The first three posts adjacent to the parapet were 2,290-mm long, W200x19 with an embedment depth of 1,605 mm. The next five posts were 1,980 mm, W150x13.5. The spacing between the first four posts adjacent to the concrete parapet was 476 mm with the spacing increased to 953 mm for the remaining posts. Backup plates were utilized between the posts and the rail starting at the fifth post from the end of the concrete parapet. All of the posts had 150-mm x 200-mm timber blockouts. Nested 12-gauge W-beam guardrail was mounted to the first five posts with single 12-gauge W-beam guardrail for the rest of the system at a height of 685 mm. A rub-rail consisting of C152x12.2 channel, was mounted using tapered wood blockouts on the first three posts and no blockout at post 4. The rub rail was bent back behind and terminated at post no. 5.

The test vehicle, a 1994 Chevrolet 2500 pickup truck with a test inertial mass of 2000 kg, impacted the transition 690 mm from the end of the bridge parapet at 101.2 km/h and at an angle of 24.7 degrees. The transition successfully contained and redirected the vehicle; however, the vehicle rolled one revolution upon exiting the transition and intruded into other traffic lanes. Due to these occurrences, this test failed to meet all of the safety performance criteria for NCHRP Report No. 350.

REFERENCES

1. Bronstad, M. E., Calcote, L. R., Ray, M.H., and Mayer J.B., *Guardrail-Bridge Rail Transition Designs, Volume 1: Research Report*, Report No. FHWA/RD-86/178, Southwest Research Institute, April 1988.
2. Bligh, R.P., and Mak K.K., *Evaluation of Tennessee Bridge Rail to Guardrail Transition Designs*, Research Study No. 7199, Texas Transportation Institute, June 1994.
3. Mak, K.K., and Menges, W.L., *Testing and Evaluation of the W-Beam Transition (on Steel Posts with Timber Blockouts) to the Vertical Flared Back Concrete Bridge Parapet*, Report No. FHWA-RD-96-200, Texas Transportation Institute, November 1997.
4. Buth, E.C., Menges, W.L., and Butler, B.G., *NCHRP Report 350 Test 3-21 of the Vertical Flared Back Transition*, Report No. FHWA-RD-98, Texas Transportation Institute, October 1998.
5. Buth, E.C., Menges, W.L., and Butler, B.G., *NCHRP Report 350 Test 3-21 of the Vertical Flared Back Transition*, Report No. FHWA-RD-99-062, Texas Transportation Institute, December 1999.

Problem # 3 – Chamfer Allowed On Temporary Concrete Barrier

State Question:

I hope this finds you all well.

Erik is out this week, so I'll apologize upfront if he has already contacted you on this question.

Attached is the SDD for our 12' -6" temp conc barrier. While we've had this standard for awhile, we were also phasing out our former 10'-0" barrier, so our experience is relatively recent.

The primary feedback we've gotten is that the new barrier is much more susceptible to breaking/spalling along the edges.

I received another phone call today that after only 2 or 3 uses they are seeing 10 -20% of the barriers showing these problems; whereas, with our 10 ft barrier they'd typically get 10 – 15 uses before seeing this kind of damage. So, they are asking if vendors can add a ¾-in chamfer to:

- The front and back bottom edges
- The vertical edges on the ends

You'll see we allow ¾-in chamfer on the bottom edge on the ends now.

Has Erik posed this question to you before?

We have 2 very large barrier projects being let this summer and fall, and contractors are saying that a lot of barrier will need to be produced very soon.

I'll appreciate your insights here, and apologize again, if you've already addressed.

Thank you,

Jerry H. Zogg, P.E.
Chief Roadway Standards Engineer

MwRSF Response:

Hi Jerry,

We have no issues with allowing the $\frac{3}{4}$ " chamfer you are requesting on the front and back bottom edges and the vertical edges on the ends. Florida has been using similar chamfers for some time now to reduce that kind of damage.

Thanks

Bob Bielenberg, MSME, EIT
Research Associate Engineer
Midwest Roadside Safety Facility

Problem # 4 – TL-2 Guardrail Installation Height

State Question:

Ron, do you know what the lowest installation height for wbeam guardrail (G41S) would be for a TL-2 application?

The reason I asked that we may be able to use this as guidance for leave in place guardrail for routine maintenance. I recall that Dean was doing research on appropriate test levels for roadways that was based on a B/C type analysis. In other words a TL-2 device could be justified on a 55+ mph roadway in lieu of TL-3. Does this sound familiar to you and is that done?

The tolerance for routine maintenance is still needed. Requiring DOTs to upgrade all guardrail that is less than 27.75" except on 3R/4R or new construction is not practical. As you already know there are many other improvements that would have much better B/C ratio. Such as horizontal curves, sight distance, and access control projects to name a few.

I believe that Karla is working on some research that is related to this issue.

Rod Lacy

MwRSF Response:

Rod,

The study you asked Ron about is not complete yet. However, we have investigated the guardrail height issue. The findings indicate that 27" should be able to work at TL-2 impact conditions. We even went as far as investigating 25" and the results were inconclusive if it had a chance of working at TL-2 impact conditions.

In addition, as written in the pre-proposal for the TL-2 MGS Bridge Rail that Kansas submitted during the past pooled fund meeting, previous testing of standard W-beam guardrail and the MGS with rail height of 27" and 27-3/4" indicate that a 27" tall MGS Bridge Rail is plausible if limited to TL-2 applications.

If you have any further questions in regards to this, please let me know.

Thanks!

Karla

Karla A. Lechtenberg, MSME, EIT
Research Associate Engineer
Midwest Roadside Safety Facility

Problem # 5 – NY Cable Terminal LON

State Question:

IF we are using the NYDOT cable barrier terminal, what is the estimated length of need for this system for impacts on both the upstream and downstream ends of the system?

Sincerely,

Erik Emerson P.E.
Standards Development Engineer-Roadside Design
Wisconsin Department of Transportation

MwRSF Response:

I reviewed the NY cable anchor report to help in the determination of the beginning of length of need for impacts on your cable terminal.

For the downstream impacts, test nos. 98 and 104 are applicable.

1. Test 98 was a 1800 lb small car impacting 39.4' upstream of the downstream anchor at 55.8 mph and 11 degrees. Test no. 98 gated.
2. Test 104 was a 1800 lb small car impacting 43.5 upstream of the downstream anchor at 61.8 mph and 15 degrees. Test no. 104 gated.
3. Test 100 was a 4780 lb sedan impacting 99' upstream of the downstream anchor at 57.7 mph and 23 degrees. Test no. 100 redirected.

Based on these tests, it appears that the minimum length that you can assume for redirection for reverse direction impacts would be greater than 43.5' upstream of the anchor. However, the minimum length from the downstream anchor where redirection will occur cannot be accurately defined from the data in the report. Test no. 100 on middle of the system LON was conducted 99' upstream of the end anchor and redirected. This would indicate that the system is capable of redirection for vehicles impacting 99' upstream of the downstream anchor. This is likely a conservative estimate, but it is all we have for a basis.

For the upstream impacts, test no. 107 is applicable.

1. Test 107 was a 4850 lb sedan impacting 38' downstream of the upstream anchor at 56.5 mph and 25 degrees. Test no. 107 redirected.

The results from test no. 107 indicate that the system is capable of redirecting impacting vehicles 38' downstream of the anchorage. The IS value for this test is approximately 9% less than the NCHRP 350. This test had a 38% higher IS value than NCHRP 350 test 3-35, so it is safe to assume that the system can safely redirect vehicles impacting a minimum of 38' downstream of the anchorage.

Thanks

Bob Bielenberg, MSME, EIT
Research Associate Engineer
Midwest Roadside Safety Facility

Problem # 6 – 27" W-beam Guardrail Testing

State Question:

Do you guys know of any successful tests on 27" W-beam per TL-3? The reason I ask the RDG makes reference to these and others are saying it has never passed at 27". If so can you provide me some basic information, ie date, TL, w-beam height, testing facility, etc.?

The RDG will specify 27.75" minimum with emphasis to use taller w-beam.

Thanks

Rod Lacy

MwRSF Response:

Rod,

Here is the information on prior crash testing of 27" W-beam guardrail that you requested.

Regards,
Karla

Karla A. Lechtenberg, MSME, EIT
Research Associate Engineer

G4 Guardrail Systems (Strong post--W-Beam with 27-in. (686-mm) top of rail height)						
Facility	Test Number	Test Date	Post Material	Blockout Material	NCHRP 350 TL-3 Pass/Fail	Reference
TTI	471470-26	4/13/90	Wood	Wood	Pass	1
TTI	471470-27	05/25/94	Steel	Steel	Fail	1
TTI	405421-2	Unavailable	Steel	Steel	Pass	2*
MwRSF	MIW-1	08/25/1999	Steel	Wood	Fail	3
TTI	405421-1	11/16/1995	Steel	Wood	Pass	4
TTI	400001-MPT1	11/13/1996	Steel	Plastic	Pass	5

*MwRSF does not have access to a copy of the report and was only able to take the information cited out of NCHRP Report 471

1. Mak, K.K., Bligh, R.P., and Menges, W.L., *Testing of State Roadside Safety Systems - Volume XI: Appendix J - Crash Testing and Evaluations of Existing Guardrail Systems*, Research Study No. RF 471470, Draft Final Report to the Federal Highway Administration, Office of Safety and Traffic Operations R&D, Performed by Texas Transportation Institute, Texas A&M University, College Station, Texas, December 1995.
2. Buth, C.E., Zimmer, R.A., and Menges, W.L., *Testing and Evaluation of a Modified G4(1S) Guardrail with W150x17.9 Steel Blockouts*, TTI Report No. 405421-2, Texas Transportation Institute, The Texas A&M University System, College Station, Texas. 1997.
3. Polivka, K.A., Sicking, D.L., Rohde, J.R., Faller, R.K., and Holloway, J.C., *Crash Testing of Michigan's Type B (W-Beam) Guardrail System*, Final Report to the Michigan Department of Transportation, Transportation Research Report No. TRP-03-90-99, Midwest Roadside Safety Facility, University of Nebraska-Lincoln, Lincoln, Nebraska, November 10, 1999.

4. Bullard, D.L., Menges, W.L., Alberson, D.C., *NCHRP Report 350 Compliance Test 3-11 of the Modified G4(1S) Guardrail With Timber Blockouts*, Texas Transportation Institute, The Texas A&M University System, College Station, Texas.
5. Bligh, Roger P. and Menges, Wanda L., *Testing and Evaluation of a Modified Steel Post W-Beam Guardrail With Recycled Polyethylene Blockouts*, Texas Transportation Institute, The Texas A&M University System, College Station, Texas.

Problem # 7 – MGS with Posts Removed

State Question:

Ron,

I think this is related to another question that I had a few weeks ago. We are putting together Tollway guardrail guidelines for designers to use. I would like to provide some guidance on conflicts with posts within a run of guardrail. We have some drainage structures that are about 9' across. If one of these drainage structures falls at a post, would it be better to just leave one post (or 2?) out or shuffle the post spacing and use all of the posts. Shifting the posts around would place posts where there are no pre-drilled holes in the rail. Is that an issue?

If post(s) are left out does anything else need to be done as long as there is plenty of room for deflection? If one post is left out, what is the anticipated deflection?

We would rather not use any special posts if possible.

Thanks again.

Tracy Borchardt
AECOM -- IL Tollway GEC

MwRSF Response:

Tracy:

The MGS Long-Span system was developed for use to span transverse culverts measuring 24 ft wide or less. In this circumstance, three posts would be removed from the system. This system also utilizes three CRT posts on each side of the culvert structure. For culverts measuring less than 24 ft wide and where one or two posts are omitted, it still would be necessary to utilize the CRTs on each side of the unsupported segment of rail.

Although it may be possible for the MGS to work with one post removed and without CRTs adjacent to the long span, it should be noted that crash testing has not been performed on this

MGS system nor to verify that acceptable performance would result. As such and in the absence of test data, we recommend that the CRTs be installed in systems where one, two, or three posts are removed.

In locations where posts are left out, dynamic barrier deflections and working widths would be expected to increase. Test results are available for the case with three posts removed from the MGS. However, data is not available for cases with one or two posts removed. BARRIER VII computer simulations could be performed to estimate barrier deflections and working widths. A small modeling study would be necessary to validate the model for the MGS long-span system and then predict barrier performance with fewer posts removed.

Ron

Ronald K. Faller, Ph.D., P.E.
Research Assistant Professor

Problem # 8 – MGS Spacing Guidelines

State Question:

Ron,

Sorry it has taken so long for me to get back to this issue. Please review the attached excerpt from the draft Tollway Traffic Barrier Guidelines manual that we are working on.

What I am proposing does not use special posts and does not eliminate any posts, but limits the maximum and minimum post spacing to try to control the changing rigidity. Let me know what you think. The max and min values are just numbers I made up for discussion purposes. They could be more or less if you are comfortable with the idea. Maybe my idea works up to a certain size drainage structure and then we go to CRT posts???

Is the purpose of the CRT to prevent pocketing?

Thanks for your help.

Tracy

Guardrail Clearance Distance

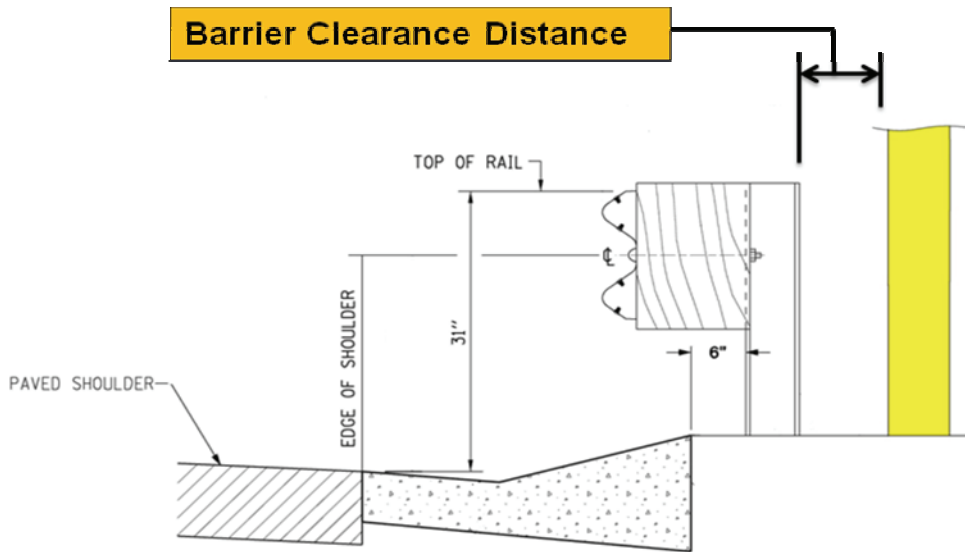

Figure x.x.x Guardrail Clearance Distance

The guardrail clearance distance is a horizontal distance measured from a line connecting the back of guardrail posts to the nearest point of the obstruction. Table x.x.x shows the desirable and the minimum clearance distances for different post spacing of the MGS. Table x.x.x shows the clearance distances for the previous (or retired) standard guardrail systems.

- The desirable distance should be provided unless a cost-effective analysis shows that it is not economical to do so.
- Obstructions should be positioned to minimize the use of close post spacing.
- Storage of material and equipment behind guardrail during construction shall be placed so that the desirable clearance distance is provided.

Table X.X Guardrail Clearance Distance			
Guardrail System	Post Spacing	Minimum Design Clearance Distance	Minimum Desirable Clearance Distance
MGS- 31" Type A	6' - 3"	28"(*)	42"
MGS- 31" Type B ½-Post Spacing	3' - 1 ½"	23"(*)	30"
MGS ¼-Post Spacing	1'-6 ¾"	14"(*)	24"

(*) Minimum design clearance distance to be used only when desirable dimensions cannot be obtained.

Table X.X Guardrail Clearance Distance			
Guardrail System	Post Spacing	Minimum Design Clearance Distance	Desirable Design Clearance Distance
Retired Standard- 27½" Type A	6' - 3"	36"	36"
Retired Standard- 27½" Type B ½-Post Spacing	3' - 1 ½"	24"	24"
Retired Standard- 27½" ¼-Post Spacing	1'-6 ¾"	18"	18"

Guardrail Post Spacing Transitions

In locations where existing obstructions cannot be offset further from the roadway to obtain the minimum required guardrail barrier clearance distance, stiffer guardrail transitions shall be accomplished through reduced post spacing. For all new installations, obstructions shall be no closer than the minimum desirable clearance distance. When the minimum design clearance distance is not obtainable, a design deviation shall be submitted to the Tollway's Chief Engineer for consideration.

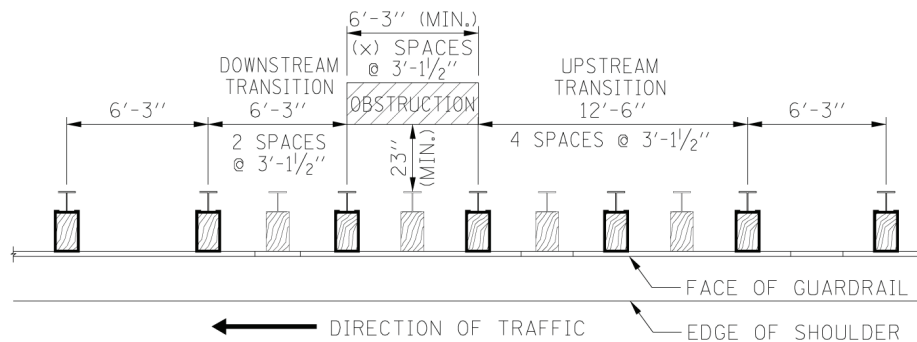

Figure 4.2-2 Guardrail Post Spacing Transition to 1/2-Post Spacing

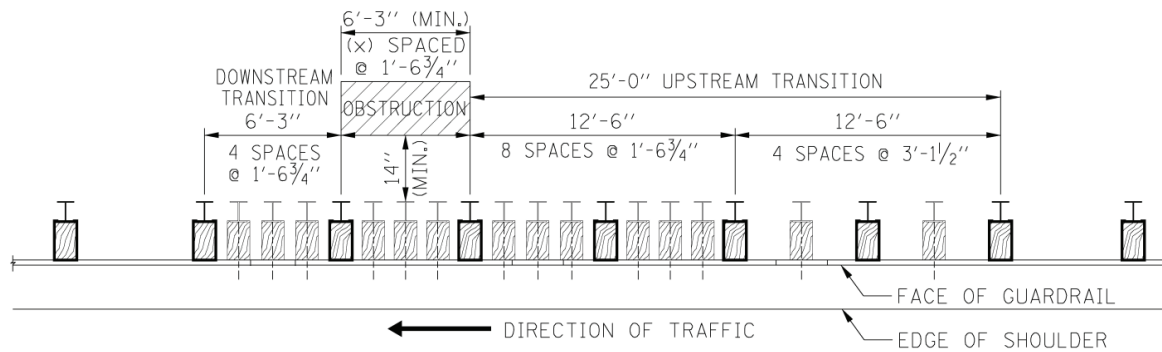

Figure 4.2-3 Guardrail Post Spacing Transition to 1/4-Post Spacing

For any obstruction with a horizontal clearance distance of less than 14", a concrete barrier wall shall be installed. Double nesting of the w-beam rail elements to stiffen the guardrail is not permitted.

Guardrail Posts Conflicts with Drainage Structures

It is not permissible to leave out any posts. Also, additional block-outs are not to be added to provide a greater offset, in order for the post to avoid an obstruction. Block-outs shall not be omitted. For Type A Guardrail, maximum post spacing shall be 9'-6" and minimum post spacing shall be 3'-0"

For Type A guardrail (6'-3" post spacing) and a drainage structure conflicts with one post.

1. Move conflicting post to the side of the structure that maintains the most even post spacing. Do not exceed maximum post spacing.
2. If maximum post spacing cannot be maintained, then move conflicting post to be adjacent to drainage structure and add one post to be adjacent to the other side of the structure. Posts should be no closer than the minimum spacing. If minimum post spacing cannot be met, then next adjacent post shall be moved to achieve the minimum post spacing. Keep post spacing as uniform as possible to reduce the potential for vehicle pocketing because of the abrupt changes in rigidity. Because the deflection of the rail will be increased in areas where post spacing is increased, the guardrail clearance distance shall be 6' minimum to any nearby hazards.

For Type A guardrail (6'-3" post spacing) and a large drainage structure conflicts with two posts.

1. Move conflicting posts to be on each side of structure.
2. Post spacing shall not exceed maximum post spacing and shall not be less than the minimum post spacing.

MwRSF Response:

Tracy,

I believe that establishing a maximum and minimum post spacing for these special applications without the need for CRT post (or other specialized posts) has merit. The minimum spacing you proposed is very near a ½-post spacing (3' vs. 3'-1.5"), thus it seems reasonable. Along the same lines, I would consider 150% of standard post spacing as an acceptable maximum spacing limit. Your proposed limit is very close to this value (9'-6" vs. 9'-4.5"), and thus also seems reasonable.

I also agree with and encourage your statement to keep the post spacing as uniform as possible in these situations in order to prevent large variations in stiffness that cause pocketing.

One important thing to note here, these post spacing variations should only be applied to standard segments of the guardrail system. Guardrail transitions and terminals are carefully

designed to accommodate increases in stiffness along the system. Therefore, these general rules do not apply and any variations to a transition or terminal need to be individually analyzed.

To answer your question about the use of CRT posts in the Long-span system – They reduce the affects of vehicle snag on the posts. CRT posts are designed to maintain bending strength about the string axis (laterally) but are substantially weaker about the longitudinal direction. Thus, when a vehicle contacts a CRT post, it will fracture or break away and consequences of vehicle snag are minimized.

I like both transitions (to $\frac{1}{2}$ post and to $\frac{1}{4}$ post spacing) and only have a few comments.

First, the distances shown from the hazard/obstruction to the beginning of the transition segments should be shown as minimums. There hazards may not line up as nicely as shown in your drawings, making these exact distances not possible. By stating the minimum lengths required you cover all situations.

Second, in circumstances where the hazard/rail is susceptible to impacts from vehicle traveling in the opposing traffic direction, you would want to make the transition symmetric about the hazard (i.e., change the downstream portion to match the upstream.

Third, the length of $\frac{1}{4}$ post spacing prior to the hazard must be greater than 7.5 ft (as determined from the full-scale test NPG-6 as the distance from contact to maximum deflection). You currently have 12.5 ft listed for this distance, thus it could be shortened slightly. I would recommend a minimum of 9 ft of $\frac{1}{4}$ post spacing prior to the hazard. However, 12'-6" is conservative and could still be used.

Let me know if you have any further questions / concerns

Thanks,

Scott Rosenbaugh
Midwest Roadside Safety Facility (MwRSF)
University of Nebraska – Lincoln

Problem # 9 – Cable Barrier Anchor Post

State Question:

Ron,

- 1.) Can the soil; plate be bolted to the post after being driven?
The installer would like to drive the post without the soil plate attached.
What size bolts and how many could be used?

2.) Post #2 – the Cable Bracket Detail shows a cut to allow a ¼” x 1.5” piece of metal cut to fold down and hold the cables in place. These break easily sometimes during installation and regularly in a crash.

Are these mainly for installation convenience?

Do these need to be in place for the guardrail to perform properly?

If they are missing does the post need to be replaced?

Is there other non proprietary/ approved methods of hooding these cables in place without being too strong?

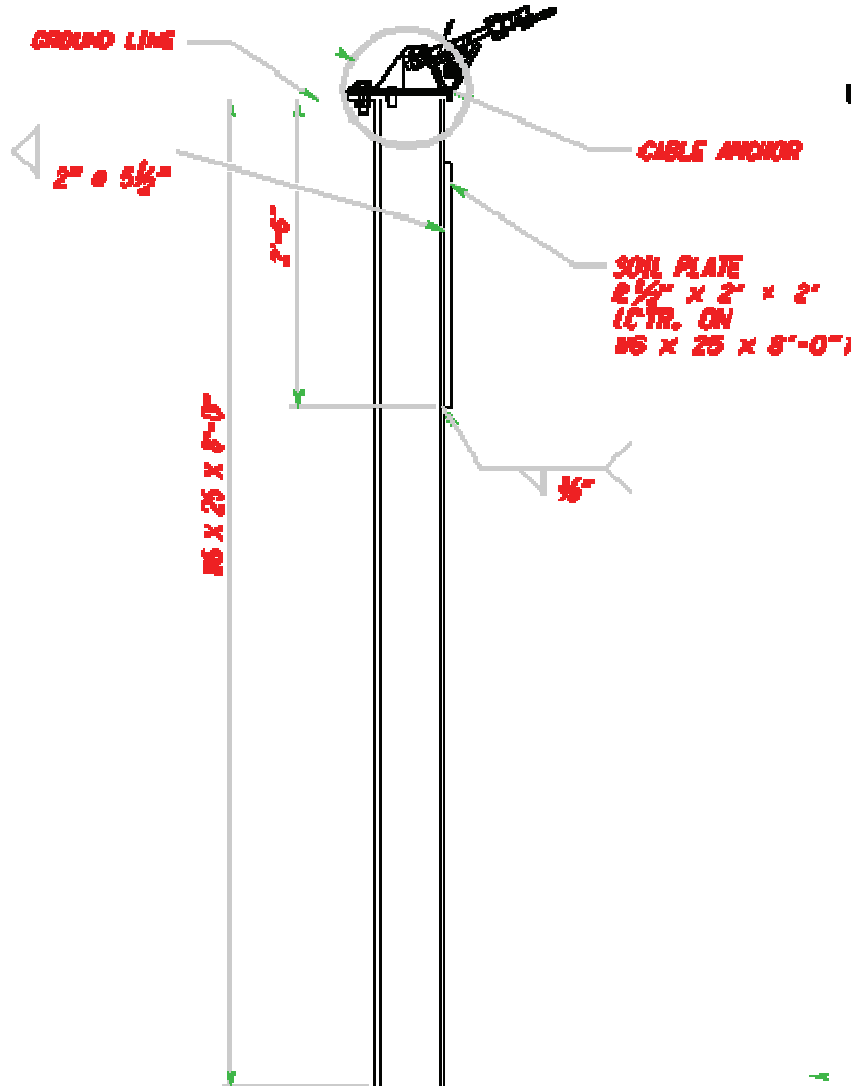

Phil TenHulzen PE
Design Standards Engineer

MwRSF Response:

Phil,

Answers to your questions...

1) Yes the soil plate can be added after the post is driven into the ground. You will have to dig a hole large enough to properly place the plate on the post – note it is 2 ft wide and extends 2.5 ft below the surface. Also, you will need to compact the soil around the post/plate when the hole is filled. Uncompacted soil will not generate the necessary resistance for the anchor. We use a pneumatic tamper and install soil in 8 inch lifts when we compact soil at our test site.

You can attach the plate to the downstream post flange using four 3/8 in. diameter bolts – two near the top and two near the bottom of the plate.

2) Leaving the slots open shouldn't negatively affect the safety performance of the system. I believe they were originally designed for maintenance issues. I am not aware of any additional approved methods of holding the cables in the slots.

Scott Rosenbaugh
Midwest Roadside Safety Facility (MwRSF)

Problem # 10 – Approach Transition Post Alternatives

State Question:

Scott/ Ron
Please review and comment.

Latest changes:
Is a w8x21 – 7' a quality substitute for the w6x25 – 7' for posts 1-3?

These match the 2000 Texas Transportation Institute TTI testing to NCHRP 350 - Contract No. DTFH61-97-C-00039 as well as letter from Ron faller – Sept 26 2002.

Posts at the end of the nested thrie-beam and through the 6'-3" single thrie-beam and 6'-3" transition to w-beam follow testing performed by MwRSF Research Report No. TRP-03-210-10 "Design K".

Testing also known as:
Midwest States' Regional Pooled Fund Research Program
Fiscal Years 2008-2009 (Years 18-19)
Research Project Number SPR-3 (017)
NDOR Sponsoring Agency Code RFP-08-05

The need for using two tests to justify the bridge approach section comes from the later test using a three beam bridge rail instead of transitioning to a concrete rail.

Phil TenHulzen PE
Design Standards Engineer
Nebraska Dept. of Roads

MwRSF Response:

Phil,

A W8x21 post has a flange width of 5.25 in. while the tested W6x25 had a flange width of 6 in. This could cause significant differences to force-deflection characteristics of these posts. This coupled with the 10% strength difference between the posts raises too many unknowns for me to say that the posts can be used interchangeably.

With your alternate assembly design when you are specifying W6x25 posts, hopefully you are putting these larger posts after the W6x15 posts. The W6x25s cannot simply replace the W6x15s (at least without component testing and analysis to show there isn't any snap problems)

Finally, one minor error I see in the drawings – the post 3'-1.5" post spacing is labeled as between post nos. 7 and 10. It should be 7 – 11. It's drawn correctly, just labeled incorrectly.

Scott Rosenbaugh
Midwest Roadside Safety Facility (MwRSF)
University of Nebraska – Lincoln

Problem # 11 – Barrier Flare Rates

State Question:

Dear MwRSF,

I have a project where project staff may have to flare beam guard at a greater rate than what is listed in table 5.7 of the RDG. What research was used to develop this table? Does MwRSF have any guidance on this topic?

Just yesterday, I was asked about flare rates for concrete barrier. Does MwRSF have some research on this topic?

Erik Emerson P.E.
Standards Development Engineer-Roadside Design

Wisconsin Department of Transportation

MwRSF Response:

Eric:

I am attaching a pdf copy of a MwRSF research report regarding flare rates. As noted in the MwRSF Report No. 157, the guardrail flare rates were determined by James Hatton, FHWA. Unfortunately, I do not believe that these flare rates were based on actual full-scale vehicle crash testing.

Later, MwRSF conducted a flare rate study involving the MGS which shown that flare rates as steep as 5:1 were acceptable. I have provided a link to download this report if you cannot find it. Of course, our guidance in this report pertains only to the MGS.

The file 'TRP-03-191-08.pdf' (86.7 MB) is available for download at
<<http://dropbox.unl.edu/uploads/20100526/38cc7bf62912409c/TRP-03-191-08.pdf>>
for the next 7 days.
It will be removed after Wednesday, May 26, 2010.

Finally, I have included a pdf copy of a journal paper covering the flare rate topic that may also provide more refined conclusions and guidance. In Section 8 of the paper and based on computer simulations, the authors note that the modified G41s may not perform effectively when installed with flare rates steeper than 15:1 under TL-3 impacts under NCHRP Report 350.

Years ago and while at TTI, Dean prepared guidelines for temporary concrete barrier. I believe those guidelines are published in NCHRP Report 358.

Please let me know if you have any further questions or comments! Thanks!

Respectfully,

Ron

Ronald K. Faller, Ph.D., P.E.
Research Assistant Professor

Problem # 11 – Guardrail Over Box Culvert

State Question:

Dear MwRSF,

A project has to install a beam guard over a box culvert. Two options would be to use the long span guard rail or attach to the box culvert using a plate. Although both alternatives are crash tested, it appears that some modification will be needed to fit the given location.

If the long span detail is used, they will not be able to get the 2' grading behind the post, Is it possible to use longer post with the long span detail?

If the beam guard post are attached to the box, the post will have to be longer than what was crash tested (see PDF). At what depth, top of finished surface to top of box, can the plate detail be used?

At the pooled fund meeting there was some discussion about changing the welding the post to the plate. Could you forward me an updated detail?

I assume at a certain point if there is adequate soil mass behind the post, could shorter post with decreased post spacing be used?

Sincerely,

Erik Emerson P.E.
Standards Development Engineer-Roadside Design
Wisconsin Department of Transportation

MwRSF Response:

Eric:

MwRSF has successfully developed and crash tested two W-beam guardrail systems to span across long concrete box culverts, such as those measuring up to 24 ft in length. For the first system, the metric-height W-beam guardrail was configured with a 27-3/4-in. top mounting height, while the Midwest Guardrail System (MGS) was utilized for the second configuration with a 31-in. top mounting height. For both designs, three 6-in. x 8-in. by 6-ft long wood CRT posts were placed adjacent to the long span using the 6-ft 3-in. post spacing. Beyond the CRT wood posts, the guardrail system was transitioned into a steel post, wood block, semi-rigid barrier system which also used 6-ft long posts and a 6-ft 3-in. post spacing. For both crash-tested systems, a region of level, or relatively flat, soil fill was provided behind the CRT wood posts.

For some situations, you noted that it may be difficult to provide 2 ft of level, or mostly level, soil grading behind the wood CRT posts. As such, your inquired as to whether the wood CRT posts could be lengthened to account for the reduction in soil resistance resulting from an increased soil grade behind these six posts, especially when placed at the slope break point of a 2:1 fill slope.

MGS

Recently, MwRSF performed limited research to determine an acceptable MGS post length for a 6-in. x 8-in. solid wood post installed on 2:1 fill slopes. Although unpublished at this time, MwRSF determined that 7.5-ft long wood posts are an acceptable alternative to W6x9 by 9-ft long steel posts when considering the 31-in. tall MGS placed on a 2:1 fill slope using a 6-ft 3-in. post spacing.

The MGS Long Span system utilizes six CRT wood posts. A CRT post's moment capacity about its strong axis of bending is approximately 81 percent of that provided by the standard wood post. In the absence of dynamic component test results, it is believed that the six CRT wood posts could also be fabricated with the 7.5-ft length when used in the MGS Long Span system. If the steep fill slopes continue beyond the location of the CRT posts, then the guardrail would transition to the MGS for 2:1 Fill Slopes using either 6-in. x 8-in. by 7.5-ft long wood posts or W6x9 by 9-ft long steel posts.

Metric-Height W-beam

For the metric-height, W-beam guardrail system configured for long-span culverts, it would seem reasonable to utilize three 7-ft long wood CRT posts adjacent to each end of the box culvert if 2:1 fill slopes are present in this region. If the steep fill slopes continue beyond the location of the CRT posts, then the guardrail would transition to the metric-height, W-beam guardrail system for 2:1 fill slopes using W6x9 by 7-ft long steel posts spaced on 3-ft 1-1/2-in. centers. However, this half-post spacing system resulted in slightly decreased lateral barrier deflections as compared to those observed for standard W-beam barriers with 6-ft 3-in. post spacing. Thus, it would also seem appropriate to provide two 7-ft long W6x9 steel posts at 6-ft 3-in. spacing (i.e., 12 ft - 6 in.) between the last 7-ft long wood CRT post and the start of the half-post spacing. Therefore, all posts beyond the last wood CRT post would be configured as 7-ft long W6x9 steel posts placed at the slope break point of 2:1 fill slopes.

It should be noted that this guidance is provided using our best engineering judgment in the absence of full-scale crash testing, computer simulation, dynamic component testing, or combination thereof. If new information becomes available, MwRSF may deem it necessary to revise this guidance. If you have any questions or comments, please feel free to contact me at your earliest convenience. Thanks!

Ron

Ronald K. Faller, Ph.D., P.E.
Research Assistant Professor

Based on the success of MGS Long-Span system, MwRSF now believes that the 1.5 m lateral offset requirement for the Metric-Height, Long-Span, W-beam Guardrail System is overly

conservative for culvert slabs covered by mostly level soil fill. As such, it is MwRSF's opinion that the minimum lateral offset between the back side of the CRT wood posts and the front face of the headwall can be reduced from 35 in. to 24 in. while providing comparable safety performance. With this adjustment, the minimum recommended lateral offset between the back side of the rail and the front face of the headwall would be approximately 48 in. or 1.22 m. for the metric-height variation. In addition, it is MwRSF's opinion that the Metric-Height, Long-Span, W-beam Guardrail System has the potential to be placed even closer to the front face of the culvert headwall. However, further reductions in the minimum lateral offset could only be evaluated through full-scale crash testing.

If you have further questions or comments regarding the enclosed information, please feel free to contact me at your earliest convenience. Thanks!

Respectfully,

Ron

Ronald K. Faller, Ph.D., P.E.
Research Assistant Professor

Eric:

Recently, you requested information regarding the soil fill depth where one would switch from the culvert-mounted, W-beam guardrail system to the standard W-beam guardrail system with posts embedded in soil without special anchorage.

Several years ago, MwRSF developed a metric-height, W-beam guardrail system for attachment to the top slab of a concrete box culvert when structure lengths exceeded 25 ft. The new design utilized an anchored post spaced on 3 ft – 1-1/2 in. centers. Each post was also configured with a welded base plate capable of absorbing energy upon impact. The testing program used a “practical” minimum soil depth of 9 in. Upon completion of the successful testing program according to TL-3 of NCHRP Report No. 350, it was recommended that the back of the posts be placed a minimum of 10 in. from the front face of the culvert headwall. A dynamic barrier deflection of approximately 16.5 in. was observed.

The noted crash testing demonstrated that the barrier system performed in an acceptable manner with 9 in. of soil fill. The researchers also believe that the barrier system would have performed in an acceptable manner with soil fill depths of approximately 43 in., thus replicating the expected safety performance of half-spaced posts used in combination with metric-height, W-beam guardrail systems. For soil fill depths of 43 in. on culvert slabs, it would seem unnecessary to utilize a barrier system with anchored posts or a half-post spacing. Instead, a standard, full-spacing, metric-height, W-beam guardrail system would be used on a culvert if adequate soil fill

depth is provided along with a minimum of 2 ft of level (or mostly level) terrain behind the posts.

If the soil fill depth is less than 43 in. but greater than 3 ft, it would seem both desirable and reasonable to use a barrier system that does not require attachment to the culvert slab. Unfortunately, no research has been performed to determine the minimum post length/embedment depth for metric-height, W-beam barriers to meet the TL-3 safety performance guidelines. However, we believe that a W-beam guardrail system with a slightly reduced post length and reduced post spacing would have a high probability for meeting current impact safety standards, especially if configured with the 31-in. top mounting height. However, satisfactory barrier performance can only be determined with the use of full-scale vehicle crash testing.

If you have further questions or comments regarding the enclosed information, please feel free to contact me at your earliest convenience. Thanks!

Respectfully,

Ron

Ronald K. Faller, Ph.D., P.E.
Research Assistant Professor

Problem # 12 – W-Beam Guardrail Near Steep Slopes w/ Wood Plank Soil Containment System

State Question:

We are developing plans for the mill and resurfacing of STH 145 from STH 100 to STH 167 in Waukesha and Washington Counties.

We have a question for you regarding the beam guard on the NB approach to B-67-217. The beam guard in question is between Sta 42+12 to 45+12, Rt. The existing beam guard has 10' posts tightly spaced and has some timber planking along the inside face more or less serving as a short retaining wall. The beam guard, posts and planking are in reasonably good condition. Our original concept was to replace the beam guard and 10' posts and saw off the old posts at the top of the planking. During the review process it was questioned whether this beam guard would be considered crash worthy? We would like your opinion as to the best way to resolve this issue.

I am attaching the following for your review:

PD01 - Plan/profile showing the proposed beam guard (Sta 38+50 to 45+00)

DT03 - Steel Plate Beam Guard Special detail
0321 - photo
Special Beam Guard Detail - from the as-built plans

Please review the information and let me know your thoughts. Thanks.

Erik Emerson P.E.
Standards Development Engineer-Roadside Design
Wisconsin Department of Transportation

MwRSF Response:

Erik:

I briefly looked over the enclosed information and have the following comments.

First, there is concern with the placement of a ground-mounted, wood rub-rail system under the guardrail that may cause an impacting vehicle to vault upward as a wheel contacts the timber member, thus increasing the propensity for a vehicle to override the guardrail or become unstable during redirection. This result would especially be of concern when the wood member vertically extends greater than 4 inches above the ground-line for standard 27" tall guardrail systems.

The use of 6"x8" by 10' long wood posts in the noted situations may also result in premature post fracture and reduced energy dissipation when the drop in back slope is minimized (i.e., embedment maximized). However, the use of a 1/2-post spacing could garner back some of the reduced capacity if premature post fracture occurs. For cases where the soil drop is maximized, the soil may yield and allow post rotation prior to reaching a wood post fracture condition. To reduce concerns for wood post fracture in these special situations, it may be preferred to utilize long steel posts which would remain intact and dissipate energy during displacement of the barrier system.

As such, there are safety concerns with using a 27" tall, W-beam guardrail system when coupled with the exposed wood plank, complicated steep slopes, wood posts, and TL-3 impact conditions with higher C.G. passenger vehicles.

If you have any further questions regarding the information contained herein, please feel free to contact me at your earliest convenience.

Ron

Ronald K. Faller, Ph.D., P.E.
Research Assistant Professor

Problem # 13 – Illinois Temporary Concrete Barrier

State Question:

Please review the attached details from Illinois. Would this barrier be acceptable in Wisconsin? I presume it is approved for use by FHWA.

The Illinois barrier does not meet the requirements of WisDOT S.D.D.s. I did a cursory review of the details and compared the details for both states. There are some differences as I outline below:

Overall dimensions are the same.

The location of the loop bars are different vertically.

Anchor locations are different.

Anchor hole size is different.

Dimensions and shape of the connecting loop bars are different.

Steel anchor stakes are different in size and shape.

Illinois shows no provision for anchoring to a bridge deck or pavement.

These are a few of the issues I spotted quickly.

If the Illinois barrier is acceptable, the field staff would be required to write a CCO in order to incorporate the details into their contracts. The two barriers could not be intermixed.

Please provide some guidance as to the use of the Illinois concrete barrier. The staff on the USH 41 projects are trying to be proactive in case this barrier does show up in this area. I don't know how the N-S Freeway is handling this situation.

Dave Buschkopf
Construction Oversight Engineer

Erik Emerson P.E.
Standards Development Engineer-Roadside Design
Wisconsin Department of Transportation

MwRSF Response:

Hi Erik,

I have reviewed the Illinois barrier detail you sent. We believe that the design will be okay for free standing applications. The design is basically the MwRSF F-shape with the Oregon connection. A few additional comments:

1. Oregon barrier and connection loops and pin were tested to 350, thus the connection should not be an issue.

2. There is a small difference in barrier connection gap between the Illinois detail and the Oregon design (1" for Oregon vs. 2" for Illinois), but this should not be a big issue. It may produce larger barrier deflections than the tested Oregon design, but would be comparable with the MwRSF F-shape. The Oregon barrier achieves its low dynamic deflections largely due to the reduction of the barrier gap.
3. Oregon barrier has more moment capacity (more longitudinal steel, farther to outside), but MwRSF barrier has met MASH with current reinforcement.
4. Longitudinal steel is placed farther out in the toe of barrier in Oregon design, but again should not be an issue. It may lead to higher deflections if toes fracture. This hasn't been a problem with MwRSF F-shape barrier testing.
5. The tie-downs systems developed to pass through the toe of the barrier will not fit in current Illinois barrier design. Thus, we do not recommend using the tie-down systems with the Illinois barrier.

FHWA approved a Colorado barrier that was very similar to the Illinois barrier design. The only real difference was the steel reinforcement which was setup to match the Oregon detail rather than the MwRSF barrier. See attached.

The difference in reinforcing steel is not a big issue as the MwRSF barrier has met MASH with current reinforcement.

The tie-down anchorage for this is very different than the MwRSF barrier.

Again, we would be hesitant to apply the MwRSF tie-down anchor systems with the Illinois barrier as detailed, but believe it should be acceptable in a free-standing configuration.

Thanks

Bob Bielenberg, MSME, EIT
Research Associate Engineer
Midwest Roadside Safety Facility

Problem # 14 – FLDOT Median Barrier

State Question:

Bob,

Please take a look at the lightly reinforced concrete median barrier shown in the attached PDF file. Have you ever seen anything like this one? What test level criteria do you think this would meet?

It is difficult to determine from the drawing, but there are three #4 longitudinal bars (one near the top and two near the bottom) shown in "Section A", which is most likely intended to resist lifting and handling stresses. Since the drawing is not to scale, the aspect ratio of the elevation view may be misleading. There are only four anchors per unit (anchors paired transversely, then spaced at +/- 10.5' o.c. longitudinally). Would this affect your opinion?

Regards,
Gevin J. McDaniel, P.E.
Senior Structures Design Engineer

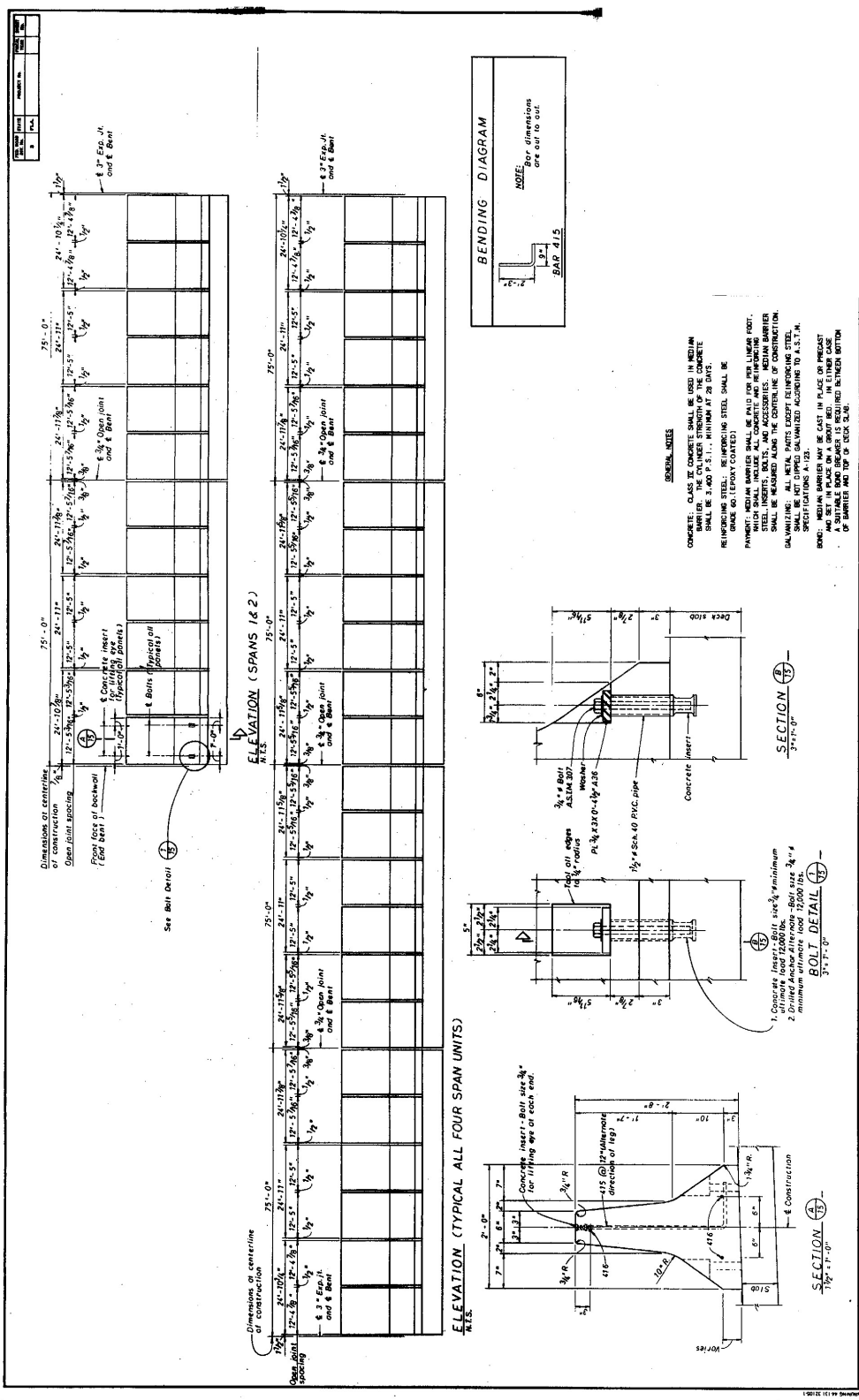

Figure 3. Median Barrier Details

MwRSF Response:

Hi Gevin,

I have looked over the median barrier detail you sent and I have some concerns with it.

1. The barrier has no longitudinal steel that I can identify. As such, the capacity of the barrier sections are very limited and you could expect a large amount of fracture and cracking in any impact.
2. It appears that the barrier sections are in segments with no connection between them. This has been shown to be very detrimental to impact performance. When a vehicle impacts one segment, you get a large shear displacement of the unconnected segment relative to the next segment downstream. This leads to snag on the downstream barrier which can cause excessive decelerations and vehicle instability. In addition, the lack of continuity between barrier segments increases the load on any one section that is impacted. Thus, with the lack of reinforcement in this barrier, you can expect an even higher level of barrier fracture and damage.
3. The anchorage capacity used for the sections is difficult to judge. The anchors do not appear to have a lot of capacity, but they are closely spaced. However, these anchors will do very little to address the two points above.

I see the longitudinal steel now. This is still a very low amount of reinforcement for a TL-3 barrier and I would still expect the damage to the concrete sections to be very high. I can only see two anchors per unit, and they appear to be 1' apart longitudinally. Additional anchorage may help on some level, but if the barrier is constrained more rigidly, the loads in the sections will increase. Thus, the lack of reinforcement becomes a more significant issue. For example, we tested the F-shape PCB section in a similar bolted down configuration at TL-3 with the 2000P vehicle, we observed cracking and fracture of the barrier section completely through the mid span of the barrier. Subsequent testing of the F-shape barrier with the 2270P vehicle has shown similar levels of damage in less constrained configurations. This PCB section has much more reinforcement and a joint connection to help distribute loads and it appears to be at or near its peak capacity. Thus I would assume that this section will not fare as well.

The concerns for lack of connection and continuity still hold true regardless. Thus, I would still be skeptical of the barrier's TL-3 performance, but there may be potential for TL-2.

I have not seen a detail like this before. I would not expect this system to pass TL-3 of NCHRP 350 or MASH. There may be some chance of it passing at TL-2, but more analysis would be needed.

Thanks

Bob Bielenberg, MSME, EIT
Research Associate Engineer

Midwest Roadside Safety Facility

Problem # 15 – Cable to W-beam Transition

State Question:

Ron,

I would like your opinion regarding a construction issue with Iowa's cable guardrail to w-beam transition (which is now voided). The standard drawing for this transition (http://www.iowadot.gov/erl/archives/2009/april/RS/content_eng/re84.pdf) is based on the South Dakota design.

'Case A' on the drawing allows one of the transition brackets to be placed on the w-beam end of the w-to-thrie transition piece. As is clear from the drawing, especially in the plan view on sheet 2, this configuration has proven very difficult to construct; the downstream post and blockout interfere substantially with the path of the cables as they travel from the transition bracket to the end anchor.

In your opinion, should we allow 'kinks' in the cables as they travel around the post and blockout? If not, would we be able to adjust the location of the transition bracket and the end anchor to provide a straight line of travel for the cables?

Thanks for your help.

-Chris

'''''' '''''' '''''' '''''' '''''' ''''''

Chris Poole, P.E.
Litigation/Roadside Safety Engineer
Office of Design
Iowa Department of Transportation

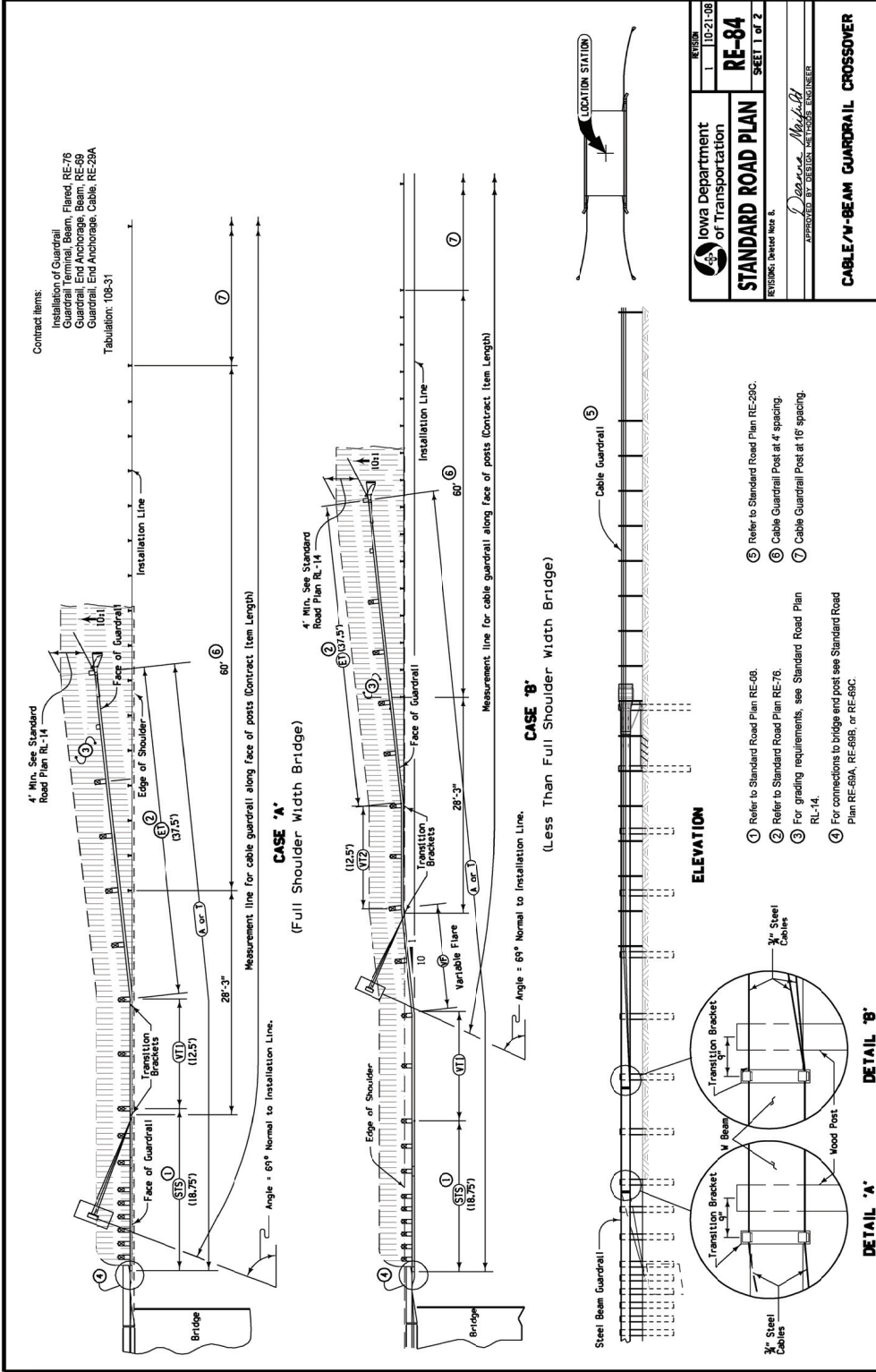

Figure 4. Cable to W-Beam Transition

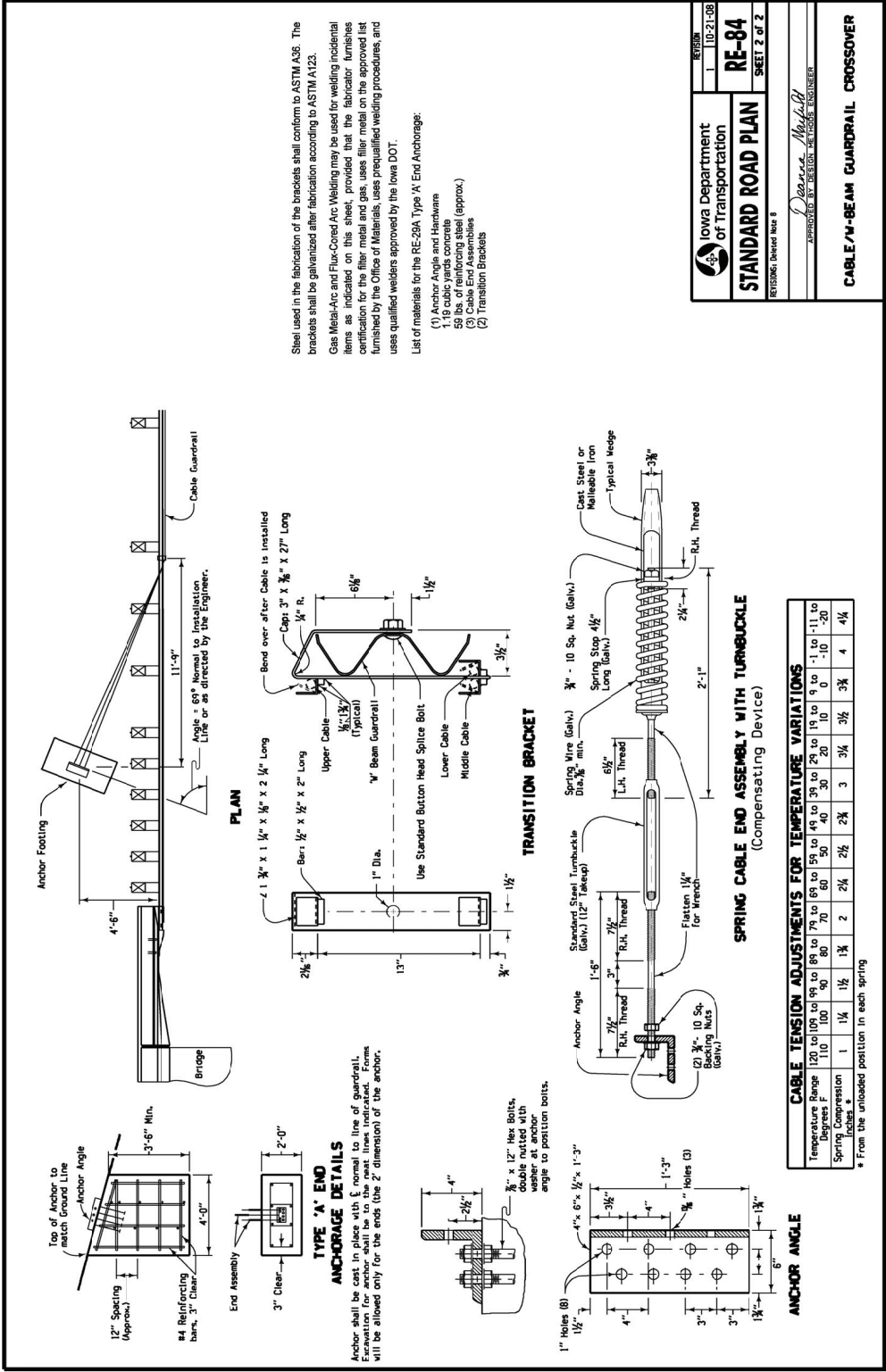

Figure 5. Cable to W-Beam Transition

MwRSF Response:

Hi Chris,

We have looked at your details and have a few comments and responses to your questions. We looked at several options for Case A in your details.

A total of four solutions were investigated. The first solution consisted of allowing the wire rope to bend around the post at the midpoint between posts at standard spacing. However, analysis of the degree of bending of the wire rope around the posts, in combination with concern that the wire ropes will either lose tension during post deflection or be pulled from the terminal, indicates that this alternative is likely not an acceptable solution without crash testing to prove crashworthiness.

The second solution proposed by the Iowa DOT was to shift the downstream transition bracket further upstream which would decrease the effective angle to the anchor bracket and allowing the cables to bypass bend locations around the post. While this design would help alleviate cable interference with the post, it is not known what the effect of shortening the overlapped cable length would have on the design. Changing the position of the transition bracket would change the angle of the cables to the ground anchor. One of the concerns in the original design of this system was the potential for snag of the vehicle in the area where the cables angle down towards the ground anchor. Thus, I am leery of changing the transitioning of the cables or the location of the anchorage without further analysis.

An additional option proposed was to drill a hole in the blockout of the post which interfered with the cables. This design option has several advantages, in that the positioning of the bracket and the W-beam do not change relative to each other, minimizing the potential for snagging, pocketing, and loss of cable tension. However, the required size of the hole required to pass the cable through the blockout would be very large, which could lead to lower compressive strength of the blockout, greater propensity for twisting, and the cables would be subject to post rotation or fracture in the soil. Damage to the post at the point of cable routing could interfere with the cable's tension and could potentially cause catastrophic release of the cable from the end terminal. Furthermore, the additional labor required for field drilling holes in the blockout and the potential to cause unexpected damage are high; therefore this is not an optimal solution.

The final design option is to add an additional 12'-6" of guardrail between the the flared crashworthy end terminal and the approach transition. By introducing an additional span of guardrail, transition bracket interference issues, cable tension concerns, and field operations are maintained. In addition, this options allows the cable transition to be completed before the approach transition to the bridge rail begins. Though this may be the be slightly more expensive option, it is nonetheless the most crashworthy from a design standpoint, and will most likely result in acceptable performance of the transition design.

An additional issue which was brought to my attention was the standard plan design of the cable anchor. This cable anchor, a 4" x 4" anchor angle, does not have sufficient strength to maintain the loads from the cables during a crash event. Cable loads on anchors can, in TL-3 crash conditions on low-tension cable guardrail systems, rise as high as 60 kips with peak loads from a single cable as high as 25 kips. It is conceivable that higher-energy impacts may cause tension increases in excess of this number. The angle bracket anchor shown in your detail will most likely not be sufficient to maintain these loads without a large degree of deformation, which may compromise the performance of the anchorage. It is recommended that Iowa adopt the design tested in the test report prepared for the South Dakota Department of Transportation entitled, "Crash Testing of South Dakota's Cable Guardrail to W-beam Transition", by Faller, Sicking, Rohde, Holloway, Keller, and Reid, MwRSF Research Report No. TRP-03-80-98. Anchor bracket design details tested in the report are attached. This design uses a gusseted anchor plate that is significantly stronger.

Let me know if you have further questions or comments.

Bob Bielenberg, MSME, EIT
Research Associate Engineer
Midwest Roadside Safety Facility

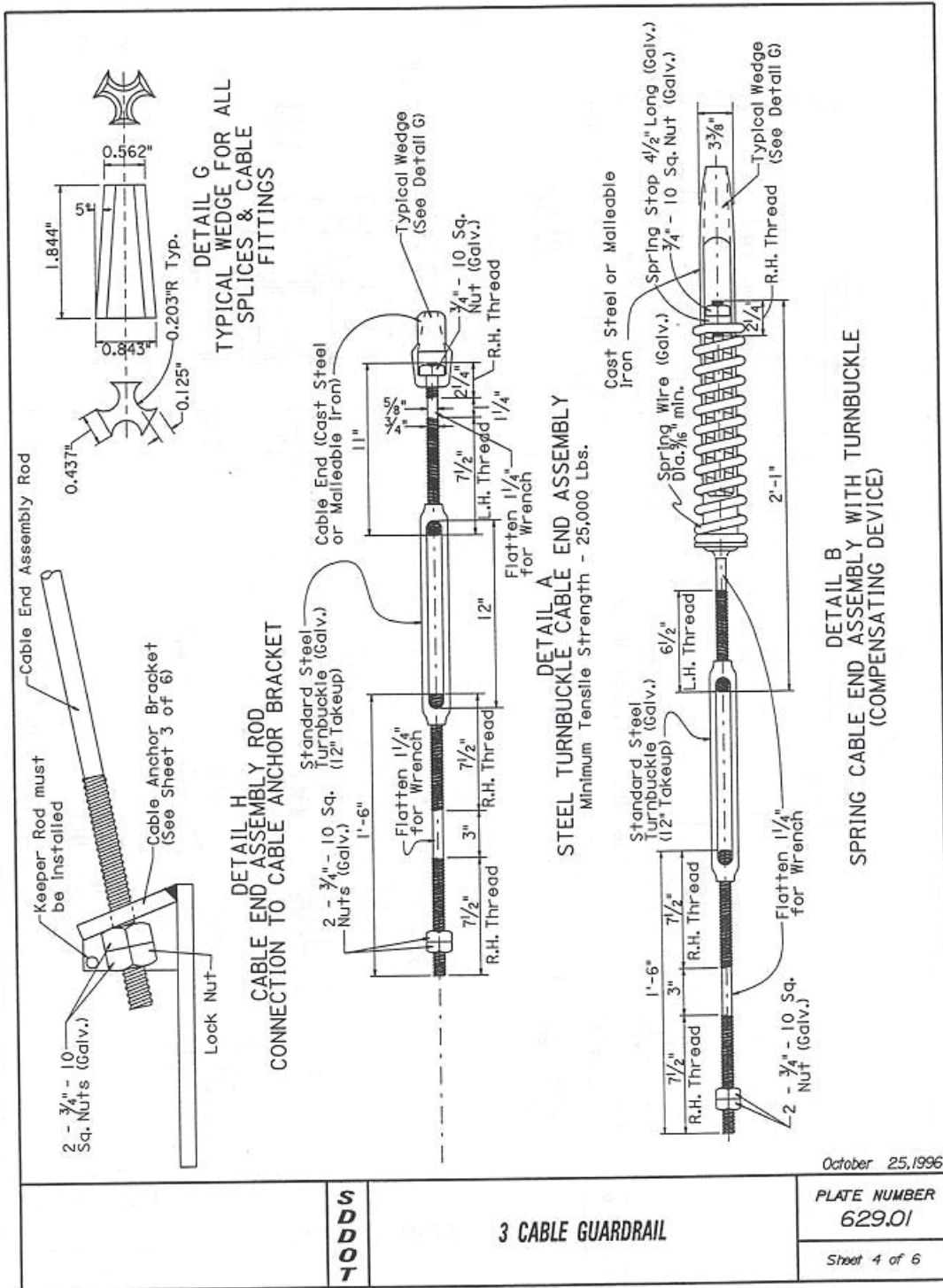

1000S	3 CABLE GUARDRAIL	
	PLATE NUMBER	629.01
	Sheet 4 of 6	

Figure 7. Recommended Cable Anchorage

Problem # 16 – ZOI – Part I

State Question:

Hello Dr. Faller,

I was wondering if you'd be able to send me your report (Guidelines for Attachments to Bridge Rails and Median Barriers: regarding the ZOI) for consideration in my review of a recent submittal for a continuous CRB median barrier that tapers up to cast-in-place 1350mm high (with a vertical face) near the location of bridge piers behind the median. I am no longer with Equilibrium and am now working on a major bridge project reviewing engineer's submittals for a different project.

The divided highway is a 90 km/hr high use one, and I have personally never seen a Vertical face barrier of 1350 high with a 453 minimum clearance (measured from traffic side to face of pier behind) ZOI behind it (610 is noted as being preferred).

In general cases, should the geometry of the vertical 1350 height face beyond the physical obstructions and the taper zone back to the typical CRB height be defined on drawings? Is 453mm an acceptable minimum ZOI?

If you can send the document by PDF, it'd be appreciated. Let me know if you have any questions, or if the above is unclear.

Regards,

Michael Roberts, P.Eng
Specialty Structural Engineering

MwRSF Response:

Michael:

I have enclosed a copy of the requested report. Please note that the ZOI information mostly pertained to test levels 3 and 4. Information for TL-5 was not determined nor provided therein. However, as barrier height is increased, the ZOI would decrease for TL-3 and 4 conditions.

Various height for rigid parapets have been used across the U.S. For TL-5 barriers, it is common to use 42" tall parapets. In addition, it is not uncommon for States to use 51 to 54" tall parapets when shielding objects or for additional glare screen protection.

Ron

Ronald K. Faller, Ph.D., P.E.
Research Assistant Professor

Problem # 17 – ZOI – Part II

State Question with MwRSF Response:

Hi Dr. Faller;

Thanks for this excellent document, most of which I am trying to use to educate and bring awareness to these important issues in my current role as Ministry liaison for review of design build submissions, however, it's again difficult given the precedences here.

****Your welcome!**

I am a member of the SEABC here in Vancouver and was wondering if you'd be interested in presenting to either the SEABC or local CSCE chapter (could be a combination) on the issues of the latest crash tested design and research findings that should become adopted in the work we are doing up here?

****Depending on the time of year and other prior commitments, I would be interested in possibly giving a technical presentation on roadside safety design to the various groups in your area. I would assume that this would correspond to a combination of topics, including ZOI concept, barrier attachments, future barrier design for head ejection, etc.**

Optimally, a tour of our area's existing and proposed highways and then being able to comment and address how they do or do not meet current safety standards would be the best as it would be both relevant and would tie in to the local needs and requirements.

****A tour of existing highways to review current design practices and challenges would be very rewarding and beneficial to focus future research efforts.**

Personally, I strongly believe that a figure like yourself to deliver this information is much overdue here in Vancouver and would have lasting impacts for both future designs and programs to address current programs. What do you think? I am sure that both the local SEABC and CSCE chapters would be able to offer good financial sponsorship (I am a member of both and am on planning committees).

****As noted above, I would be interested in further exploring whether this visit, presentation, and tour would be viable. The major hurdle for me would be the inability to cover the significant travel costs. MwRSF would not be able to cover these expenses for me. I would consider using my personal vacation time to make the trip if we both feel that this effort would help move roadside safety design forward in your region.**

Lastly, some questions related to ZOI and traffic barriers;

1. Treatment of CRB placed up against MSE (concrete panel) walls parallel to traveled highways (I.e. Are barriers even needed, should the MSE wall be designed for Impact, or just be designed for repair, panel replacement)

****Does CRB stand for a permanent or temporary concrete barrier – either precast or cast-in-place? Regardless, MSE walls would not need to be shielded unless done so to: (1) prevent vehicular impacts into MSE walls located within clear zone if the crash results in serious safety risks to motorists; (2) prevent significant repair costs to MSE wall panels, if found to occur; or (3) prevent structural damage to highway/roadway infrastructure located above as well as to surrounding motorists - adjacent and above.**

****It should be noted that TTI researchers are currently conducting a research study pertaining to vehicular impact into MSE walls. I do not have any results from this study but would recommend that you contact Dr. Roger Bligh at TTI for further details.**

2. Some of our drawings show a 1.0m sliding distance for divided highway precast CRB's. If the sliding distance is reduced at overpass columns in the centre, should there be a transition detail from free to fixed? (Current details seem to show a rising of the height to vertical 1300mm high barriers).

****If temporary or portable concrete barrier are installed in a free-standing manner, then the location of discrete fixed objects on the back side could have serious consequences. Free-standing, portable concrete barriers move laterally when impacted. Vehicle redirection occurs as a result of the inertial resistance of the barrier, the axial tension developed throughout the long, inter-connected barrier system, and the friction developed between the barrier base and the support surface. If barrier movement is restricted at discrete locations, vehicle could pocket into the barrier, snag on barrier components, override the barrier, become unstable upon redirection, etc. Depending on the location of the fixed object, transitioning of the barrier system from free-standing to fixed may be required. Some barrier systems may have options for transitioning the lateral barrier stiffness, others may not.**

****I am not sure how the rise in barrier height corresponds to the placement of hazards and free-standing and rigid barriers. Can you provide further details regarding the situation to which you refer?**

3. Do you have any information on the California 60G barrier Design, and what levels of Crash testing it meets (I.e. CAN/CSA-S6-06)?

****CALTRANS has conducted significant research on a family of single-slope concrete barriers. The research results from these crash testing programs are contained on two different locations of their website. Actual research reports and crash videos are available. I will ask that one of my colleagues sends to you the links if you are unable to locate them.**

http://www.dot.ca.gov/research/researchreports/dri_reports.htm

<http://www.dot.ca.gov/research/operations/roadsidesafety/index.htm>

****Scott – do you have any additional information on the Type 60G barrier?**

4. Are you familiar with the ZOI TL-4 of 230mm from Keller, Sicking, Polivka, and Rohde, feb 26-2003 document: do any of your findings disagree with this?

****I do not understand your question. MwRSF prepared a TL-4 ZOI chart for concrete parapets based on a review of research findings available at that time. No new study has been performed**

to review and/or update the prior findings. As such, they stand as prepared until further research is funded.

5. Is it normal practise to reduce shoulder widths at underpass column support locations on divided highways (>80kM/hr): what is the absolute unsafe minimum that should be accommodated in these types of situations.

**Unfortunately, I do not have an answer to this question and must defer to any guidance provided within the AASHTO document entitled, “A Policy on Geometric Design of Highways and Streets.”

Please let me know if you have further questions or comments. I will be out of the office next week.

Ron

Please let me know if you can answer some of teh above and advise me on your opinion of the proposed presentation.

Best regards,

Michael Roberts, P.Eng
Specialty Structural Engineering

Problem # 18 – Cable Barrier Adjacent to Slope

State Question:

Ron,

Could we simulate a cable guardrail 2' from the edge of a 2:1 slope?

Was this simulated a few years ago with the NCHRP 350 vehicles when the testing was performed on the flat to a 1.5:1 slope?

What effect will using the MASH 09 vehicles have on these previous simulations?

I would like to keep the front tire on the slope by simulating our typical cross section a 4% shoulder slope in front of the guardrail. The 2' behind the cable we normally break to a 6:1, then the 2:1 slope.

When we place cable guardrail 2' from a 2:1 our plan specifies S 3 x 5.7 x 7' posts with soil plates on 16' max. spacing.

The new inline end section is what we would use in the future to anchor this – if this makes a difference.

What would help this placement?

Closer post spacing?

Phil TenHulzen PE
Design Standards Engineer
Nebraska Dept. of Roads

MwRSF Response:

Hi Phil,

I will try to address some of your questions below

Thanks

Bob Bielenberg, MSME, EIT
Research Associate Engineer
Midwest Roadside Safety Facility
527 Nebraska Hall
Lincoln NE, 68588-0529
402-472-9064
rbielenberg2@unl.edu

From: TenHulzen, Phil [mailto:Phil.Tenhulzen@nebraska.gov]
Sent: Friday, June 04, 2010 1:34 PM
To: Ronald K. Faller
Subject: Cable guardrail 2' from 2:1

Ron,

Could we simulate a cable guardrail 2' from the edge of a 2:1 slope?

- Yes, we can simulate the cable guardrail 2' from the edge of a 2:1 slope. We proposed similar research regarding a low-tension version of the 4 cable median barrier at this year's Pooled Fund meeting. The cost for this kind of analysis would be in the \$35K range to do the analysis. If you want to formally address this, we can develop a proposal and budget. The simulation analysis will provide guidance on this issue, but full-scale testing will likely be required in order to fully address this issue.

Was this simulated a few years ago with the NCHRP 350 vehicles when the testing was performed on the flat to a 1.5:1 slope?

- The simulation effort for the 1.5:1 slope was done using Barrier VII and would not address some of the slope changes you are proposing. The previous analysis looked

solely at the effect of reducing the post spacing on barrier deflection and did not address the interaction of the vehicle and slope.

What effect will using the MASH 09 vehicles have on these previous simulations?

- Using the 2270P vehicle would likely result in additional barrier deflection. In addition, the higher CG for the 2270P vehicle could potentially adversely affect the capture of the vehicle we saw in our previous testing of the 2000P adjacent to the 1.5:1 slope.

I would like to keep the front tire on the slope by simulating our typical cross section a 4% shoulder slope in front of the guardrail. The 2' behind the cable we normally break to a 6:1, then the 2:1 slope.

When we place cable guardrail 2' from a 2:1 our plan specifies S 3 x 5.7 x 7' posts with soil plates on 16' max. spacing.

- This type of installation could be modeled. However, based on our previous experience with the 2000P testing on 1.5:1 slope, the cable barrier might require reduced post spacing to effectively capture the vehicle.

The new inline end section is what we would use in the future to anchor this – if this makes a difference.

What would help this placement?

- Lots of factors including, cable tension, post spacing, cable spacing, and post offset could all have effects on this type of installation.

Problem # 19 – Two Loop PCB Connection

State Question:

Ron,

Has MwRSF tested a 12.5' Concrete Protection Barrier with two loops?

I'm thinking this is from the 2001-2003 era.

Have we tested two loops in the end of a concrete bridge rail or median rail?

I thought we tested this with the Kansas style staked-down with 3 stakes on the traffic side.

Then 2 barriers staked down with 2 stakes each, then 1 or 2 staked down with 1 stake.

What was the name of this research study?

Would the tied down barrier move less than the free standing barrier and put less force on the loops?

Phil TenHulzen PE

Design Standards Engineer

Nebraska Dept. of Roads

MwRSF Response:

The original 350 testing utilized 2 loops per end. Later, we added the third loop to get double shear – top and bottom.

The only 2-loop TCB system that was crash tested and evaluated while anchored corresponded to the steel tie-down strap system. And, this TCB used a version where each loop was configured with 3 small bent rebar. All of tied-down systems and transitions used the Kansas version with 3 rebar loops per barrier end.

Without detailed analysis, I believe that an anchored TCB would encounter reduced tension within the loops as compared to a free-standing TCB. However, the loops would potentially experience increased shear and moment at the concrete interface if one barrier shifts relative to the other. This shifting has been observed in the anchored barrier testing. Please note that no directed study has been made for comparing the various loop configurations under free-standing and anchored installations.

Ronald K. Faller, Ph.D., P.E.
Research Assistant Professor

Problem # 20 – MGS Lower Height Tolerance

State Question:

With the improvements in the MGS, how much down tolerance do we have? Will it pass at 27” or lower?

I understand that in light of the G41S tests that got raised to 27 ¾” by virtue of metric rounding for English units. So how far down do you think the MGS could really go since it is a much better system than the G41S. Is it worth doing some modeling or testing. The reason I ask is in regards to maintenance activities, leave in place on future 3R projects, etc.

Rod Lacey

MwRSF Response:

Rod:

We have been recommending a downside tolerance of 27¾ in.

My opinion is as follows:

MASH – maybe 27” to 27½”

NCHRP 350 – maybe 27½” to 27¾”

Ron

Ronald K. Faller, Ph.D., P.E.
Research Assistant Professor

Problem # 21 – Barrier Protection in Median Crossovers

State Question:

Ron & Bob,

You will recall the question I asked about the need for barrier protection at median crossovers during our discussion Wed afternoon. As I mentioned, this question has been raised at the director level, and I will need to report back to them within the next 2 weeks. You both provided some excellent insight and perspectives that Erik, Bill and I were very satisfied with; however, I would like to pose this question again as a consultant request for a more formal response.

Like many states, we build median crossovers during construction to shift traffic from one set of pavements to another. Occasionally, we decide to leave these crossovers in-place rather than remove them at the end of the project. A question has been raised as to whether these median crossovers should have some sort of barrier protection or just delineated. It has been suggested that we install end protected temporary concrete barrier at these crossovers as soon as possible. Others have suggested we investigate installing cable barrier at these locations. I believe that some think having a paved surface connecting the two roadways poses a greater risk for a CMC; and therefore protection is warranted. I don't believe this question is directed providing a safe, proper design for the crossovers. I think that is a separate issue.

I've been asked to report on this issue in about 2 weeks at our May Safety Engineering Executive Group meeting that is comprised mostly of directors within our Division.

Thank you,

Jerry H. Zogg, P.E.
Chief Roadway Standards Engineer
Bureau of Project Development

MwRSF Response:

Jerry:

During your recent visit in Lincoln, Dr. Sicking, Mr. Bielenberg, and myself met with Mr. Emerson, Mr. Bremer, and yourself to discuss the status of the Wisconsin DOT safety research

projects. Toward the end of our meeting, you later sought comment on a potential issue involving the long-term presence of temporary and/or permanent median crossover roads between divided highways.

Median crossover roads are often used to transfer motor-vehicle traffic to the opposing vehicle lanes when construction and/or maintenance operations require the closure of selected traffic lanes found ahead. The majority of these crossover roads are typically used for short-term operations. Typically, these temporary roads are removed; however, some of these roads are occasionally allowed or intended to remain in place within the median region even though their use is discontinued. Crossover roads often remain in place due to their future use in maintenance operations or due to the high cost to remove them. Under these circumstances, questions have been raised as to whether there exists a significant risk or opportunity for motorists to utilize these crossover roads, thus potentially resulting in crossover median crashes. In addition, these questions have led to further discussions on whether the remaining crossover roads need to be protected with median barrier systems, thus preventing vehicles from traveling on the closed roads and into opposing traffic lanes.

If crossover roads must remain in place, several options should be considered for reducing or eliminating concerns for their non-approved use by motorists.

First, it may be possible to cover and/or camouflage the crossover roads with soil and vegetation to eliminate concerns for their use by motorists. Crossover roads that are covered and more closely resemble the natural median conditions should provide no greater risk of accidental vehicle crossover than the adjacent upstream and downstream median regions. If the roads are ever needed in the future, the soil and vegetation could be removed to expose the paved road surface.

Second, if complete coverage of the crossover roads is not feasible, then partial removal of the crossover road surfaces could be considered for the first 4 to 6 ft laterally away from the outer edges of the paved median shoulders. With a 4 to 6 ft width of soil region (or other width yet to be determined), grass vegetation could be used to visually close off the roads to deter their potential use by motorists.

Third, it may be reasonable and economical to line the center region of the crossover road system with a row of closely-spaced traffic delineator posts in a pattern that runs parallel to the divided highways. A row of traffic delineator posts would be highly visible during the day as well as the night and would denote to the motorists that the roads are not for public use. If truly deemed necessary, traffic warning signs could also be strategically located to further inform motorists that the crossover roads are not for public use.

Some have suggested that median barriers should be used to close off the crossover roads in order to prevent motorists from intentionally (i.e., for turning around) or accidentally (i.e., due to driver inattention) traveling on these roads. However, the use of new containment barriers at these locations would result in new risks to motorists in errant vehicles as compared to their non-

use. If barriers are not used in the median regions adjacent to the crossover roads, it would also seem inappropriate to locate barriers only across the region of the crossover roads. In addition, you noted that no accident data currently pointed to concerns at these crossover road locations. Thus, I would not recommend the use of short median barriers to cover crossover roads unless future research studies reveal that it is cost-beneficial to shield median crossover roads.

If you have any questions or comments regarding the information included herein, please feel free to contact me at your earliest convenience. Thanks!

Respectfully,

Ron

Ronald K. Faller, Ph.D., P.E.
Research Assistant Professor

Midwest Roadside Safety Facility (MwRSF)

Problem # 22 – Motorcycles and Pavement Drop-Offs

State Question:

Can you recommend good research for us to review regarding edge drops and motorcycles? Of special interest is the milled edge at lane or edge locations.

David L. Piper, P.E.
Safety Implementation Engineer
Bureau of Safety Engineering

MwRSF Response:

Hi Dave,

I do not know of any specific studies regarding motorcycles. I sent an email to Dr. Clay Gabler at VT who has done a large amount of motorcycle accident research. If anyone knows about a motorcycle accident study in this area, it would be him.

His reply was as follows.

“I can see how motorcycle and a pavement edge dropoff could be a tough problem. Probably even tougher than a car which attempts to steer too quickly back onto the highway after going off the pavement edge. However, we have not come across any studies to date on the motorcycle crashes involving pavement dropoff. Likewise, none of the crashes that we have investigated to date have involved this as a crash causation mechanism. “

At this time, it doesn't appear that there is much guidance or study in this area. I will keep a lookout for studies and let you know if I find any.

Thanks

Bob Bielenberg, MSME, EIT
Research Associate Engineer
Midwest Roadside Safety Facility

Problem # 23 – Single Slope Barrier Question

State Question:

Hello all,

On page 2 of 2 in the pdf named rm43_jan07 there is a requirement to construct a reinforced end anchorages at all expansion joints. When the barrier wall abuts a inlet that requires a expansion joint on each end (I-2.1_jul05_v8.pdf) an end anchorage would be required on both sides. Our previous drawing rm-4.3_4-18-03.pdf did not require an reinforced end anchorage but the note on page 1 of 2 labeled End Anchorage required "all horizontal rebar through a permissible construction joint to continuously reinforce abutting barrier".

Do you have any information or testing on why this change would have been made?

If 57" single slope barrier wall is being constructed with no rebar or foundation and abutting reinforced inlet with foundation separated with a .75" expansion joint; what would be your opinions on performance, TL, snagging potential, etc. This barrier is TL-5 along a continuous run but what would be the rating if ending the barrier run with no foundation or rebar?

Thanks for your time.

Michael Bline
OhDOT

NOTES

SINGLE SLOPE CONCRETE BARRIER may be cast-in-place or slip formed. See Sheet 2 for Types C and CI. See SCD RM-4.5 for Type D barrier. See SCD RM-4.6 for End Sections.

MATERIALS: Construct using Class C aggregate. Construct top and end edges with either a 1" (25) radius or 3/4" (19) chamfer, except at light pole foundations.

CONTRACTION JOINTS: Maximum allowable spacing of unsealed joints is 20' (6.0 m) throughout the run of the barrier. Construct joints by using metal inserts inside the forms, preformed full width joint filler, a grooving tool, and a saw cut. Seal joints with a sealant. Construct all joints for the full height of the barrier. Saw as soon as concrete will allow to prevent spalling. When used in conjunction with concrete pavement, match joints to those in the concrete pavement but not exceeding the maximum allowable spacing.

ADJOINING PAVEMENT: When the barrier is constructed in conjunction with existing pavement, the barrier shall be constructed against the existing pavement with a continuous wedge of surface material tapering from a minimum thickness at the top of the barrier to zero. For unidirectional installations, construct the wedge on the traveled way side and the width may be reduced to 12" (300) minimum. For new concrete pavement, place it directly on the base material. Construct the concrete abutment against the barrier.

SEALING JOINTS: Use a butt longitudinal joint between the barrier and adjoining concrete pavement sealed with CMS 705.04 joint sealer. See detail on Sheet 2.

TRANSITIONS: Make linear transitions between different types of barrier within a 20' (6.0 m) length.

CONSTRUCTION JOINTS: Barrier runs with abutting vertical surfaces to each other by use of 3/4" (19) dia. by 18" (450) long epoxy coated deformed dowel bars as per CMS 622.02. Bars are to be placed as shown in the RACEWAY BARRIER Placement Plan detail on this sheet. Provide a 4" clearance to barrier address and to any raceways.

STATION MARKINGS: Impress markings in the "green" concrete on both sides at the top of the barrier. The cost is incidental to the unit cost bid for this barrier.

RACEWAY: Locate as shown on the RACEWAY PLACEMENT Detail, unless otherwise shown. Ensure that the electrical raceway is clear of obstructions. Cost of the 4" (100) polyvinyl chloride raceway is included where shown on the placement detail. Also include the cost of 10 AWG copper shielded or plenum-rated wire, as also included where shown on the plans for future installation of circuits.

PAVEMENT will be made at the unit price bid per Foot (Meter) for Item 622 - Concrete Barrier, Single Slope, Type _____. Include all materials, labor, raceways, dowel holes, markings and other incidentals necessary to construct the barrier, except as follows:
 Item 604 Barrier Median Inlet 20 ft. (6 meters)
 Item 625 Light Pole Foundation or Pullbox 10 ft. (3 meters)
 Item 630 Barrier War Assembly 10 ft. (3 meters)
 Item 631 Barrier War Assembly 10 ft. (3 meters)
 Details shown on sheet 2 will be bid per Foot (Meter) for Each. Each for Item 622 - Concrete Barrier End Anchor, Reinforced. This includes all materials, labor, and other incidentals necessary to construct this anchor.

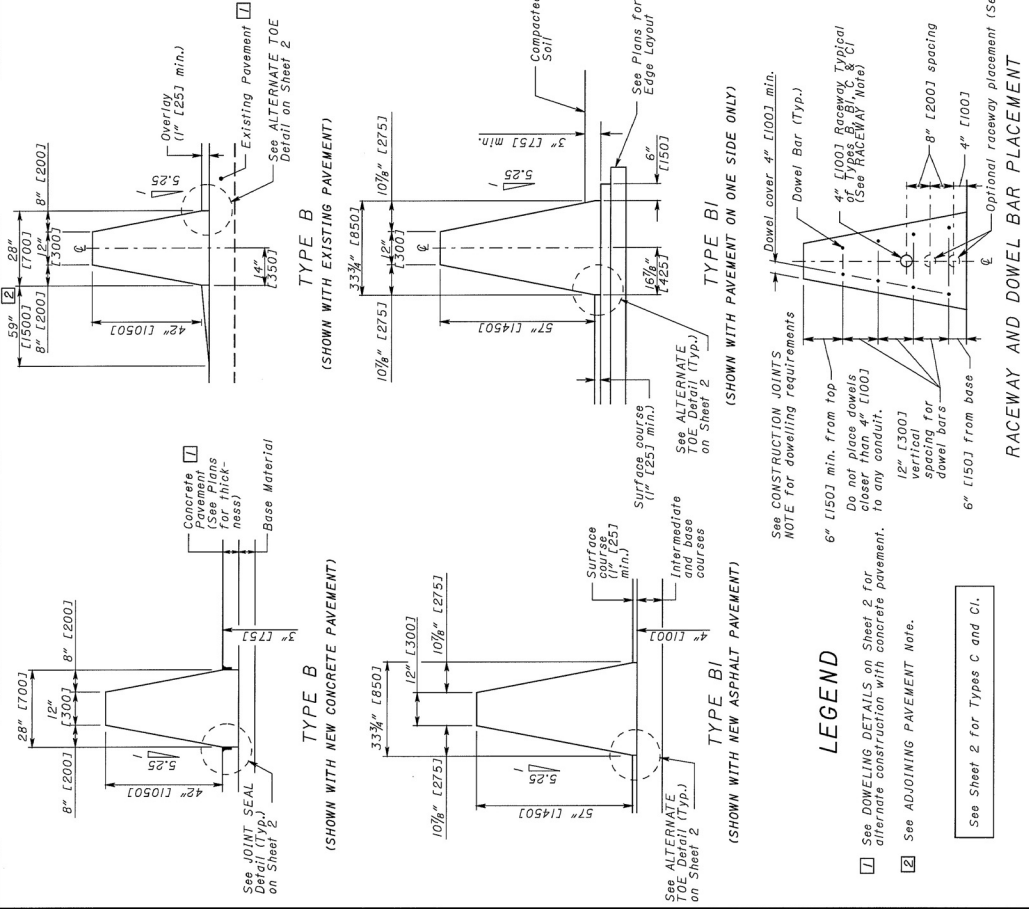

Figure 8. rm43_jan07.pdf

THIS DRAWING REPLACES RM-4.3 DATED 4-18-03.

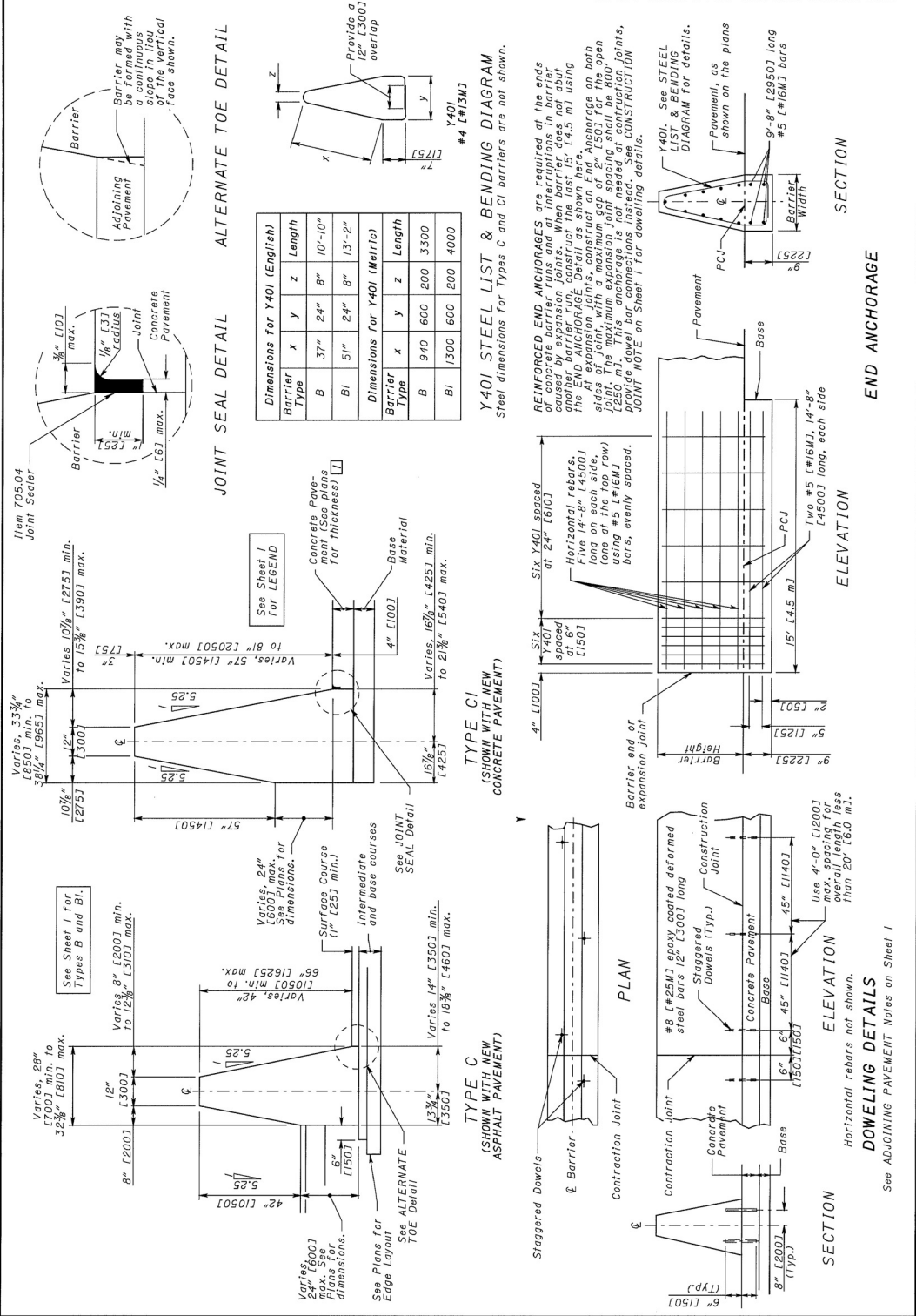

Figure 9. rm43_jan07.pdf

NOTES

GENERAL: For details of Single Slope Concrete Barriers, see SCD RM-4.3.

WALLS: The walls between the bottom slab and the upper permissible concrete shall be cast in place. The walls shall be cast in place concrete on 1200 nominal thickness formwork. The walls shall be reinforced sufficiently to permit shipping and handling without damage. The unit above the upper permissible construction joint may be precast or cast-in-place.

CONCRETE: Cast-in-place concrete is to be Class C. All precast concrete shall be Class C. The concrete shall be cast in place and shall be finished with an approved sealer.

REINFORCING STEEL: Reinforcing steel shall be epoxy coated in accordance with CMS 509.03.

CASTINGS: Minimum mass of frame and cover shall be 540 lbs. (245 kg). See sheet 2 for Casting Details.

Lighter weight frames and grates that meet the requirements of CMS 711.4 shall be used. The weight of the grates shall not differ from those shown, unless otherwise shown in the plans.

STEPS: Steps shall be in accordance with SCD MH-1.1.

INLETS OVER 12 FEET (3.5 m) IN DEPTH: Such inlets shall be precast or cast-in-place concrete, reinforced with #5 (16mm) bars on 12" (300) centers from top to bottom, vertically and horizontally with 2" (50) clearance from the inside wall face.

OPENINGS: Pipe openings shall be the outside diameter of the pipe being supplied plus 2" (50) when fabricated or field cut. Fill any voids per CMS 601.

PCB: Permissible construction joint.

PAVEMENT: Pavement will be made of the unit price bid per foot. For this INLET, No. 3 for Single Slope Barrier, Type A, B, or BI and shall include all materials, reinforcing steel, castings, raceways, wiring and labor required to construct the inlet as shown.

LEGEND

1 After casting is placed, fill notch with Class C concrete.
 2 1/2" (38) minimum exp. joint shall be provided in concrete pavement or concrete shoulders.
 3 4" (100) electrical raceway for Types B & BI. See Sheet 2 for RACEWAY PLACEMENT Details.

STANDARD INLET TYPES					
INLET NO. 3	W	H	A	B	BI
Type A	8" (200)	42" (1060)	6" (150)	24" (600)	24" (600)
Type BI	8" (200)	57" (1460)	3 1/2" (75)	29 3/4" (750)	29 3/4" (750)
Type B	12" (300)	42" (1060)	4" (100)	28" (700)	28" (700)
Type BI	12" (300)	57" (1460)	3 1/2" (75)	33 3/4" (860)	33 3/4" (860)

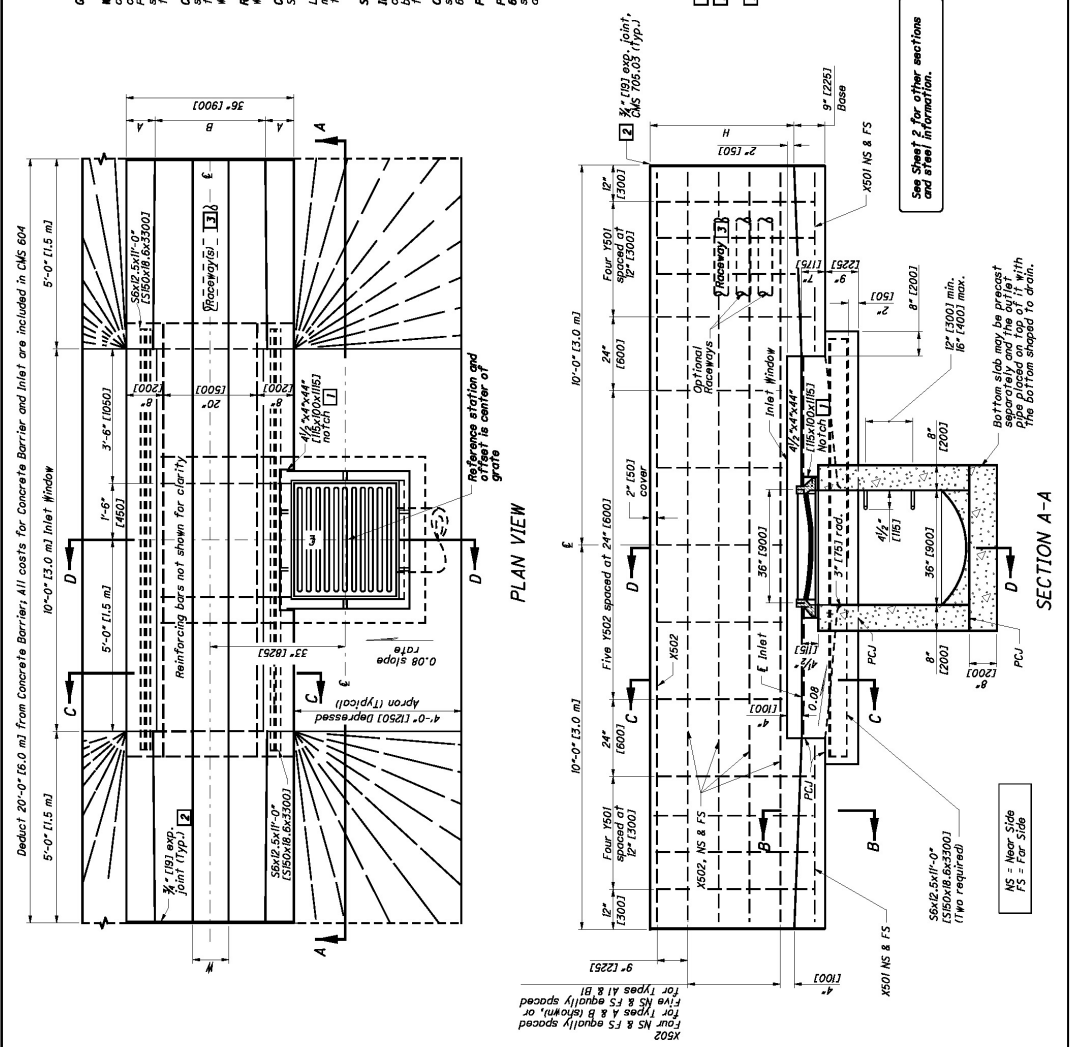

GENERAL: Deduct 20'-0" (6.0 m) from Concrete Barrier and Inlet are included in CMS 604

10'-0" (3.0 m) Inlet Window

5'-0" (1.5 m)

3'-5" (1050)

1'-6" (450)

Reinforcing bars not shown for clarity

33" (825)

0.08 slope

Apron (Typical)

4'-0" (1200) Depressed

58x12, 6x11, 0" (1580x18, 6x3300)

3/4" (19) exp. joint (Typ.)

4 1/2" (115) x 44" (1118) x 100" (2540) notch

Reference station and inlet are center of grate

10'-0" (3.0 m)

10'-0" (3.0 m)

10'-0" (3.0 m)

12" (300)

Four 1501 spaced at 24" (600)

24" (600)

Five 1502 spaced at 24" (600)

24" (600)

2" (50) cover

Optional Raceways

Inlet Window

1/2" (12.5) x 44" (1118) x 100" (2540) notch

1/2" (12.5) x 44" (1118) x 100" (2540) notch

9" (225) Base

X501 NS & FS

8" (200)

12" (300) min. 1/8" (3.0) max.

8" (200)

8" (200)

PCU

PCU

See Sheet 2 for other sections and steel information.

Bottom slab may be precast separately and the inlet pipe placed on top of it with the bottom shaped to drain.

X502 Four 1501 spaced at 24" (600)

12" (300)

9" (225)

X501 NS & FS

58x12, 6x11, 0" (1580x18, 6x3300) (Two required)

MS = Near Side
 FS = Far Side

Figure 10. I-2.1_jul05_v8.pdf

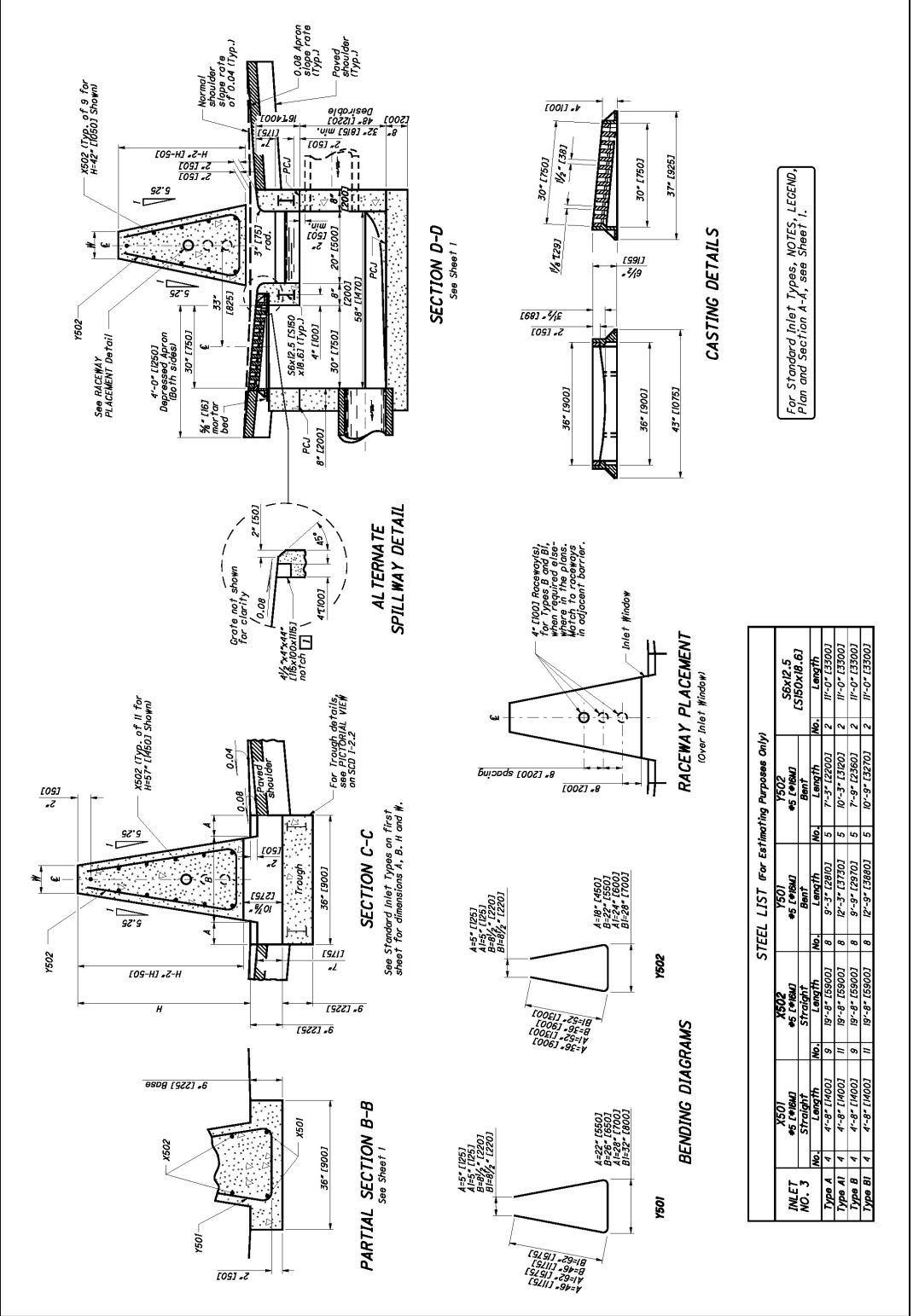

Figure 11. I-2.1_jul05_v8.pdf

THIS DRAWING REPLACES RM-4.3M DATED 10-21-97.

NOTES

SINGLE SLOPE CONCRETE BARRIER may be cast-in-place or slip formed. See Sheet 2 for Types C and CI. See **SCD RM-4.5** for Type D barrier.

MATERIALS: Construct using Class C concrete. Construct top and end pole foundations using a 1" (25.4 mm) diameter, except at right angle intersections. All rebar is to have 3/4" (19.0 mm) diameter. On barrier types defining rebar, use epoxy coated Grade 60 (E420 MPa) rebar. For dowel bars, use 1/2" (12.7 mm) diameter. For all other rebar, use 3/4" (19.0 mm) diameter. Any method devised by the contractor that will assure the horizontal steel will be positioned 1/2" (12.7 mm) as dimensioned will be satisfactory. Vertical steel within tolerances only to the extent necessary to position horizontal steel within tolerances through contraction joints. Minimum rebar lap splices shall be 15" (381 mm). Welding of reinforcement is prohibited (CMS 505.04).

CONTRACTION JOINTS: Maximum allowable spacing of unsealed joints is 20' (6.1 m). For sealed joints, maximum spacing shall be 10' (3.0 m). Sealant shall be applied to the joint after the concrete has cured. Sealant shall be applied to the joint after the concrete has cured. Sealant shall be applied to the joint after the concrete has cured.

ADJOINING PAVEMENT: When the barrier is constructed in conjunction with existing pavement, the barrier shall be constructed on a continuous wedge of surface material tapering on the side of the barrier. For bidirectional installations, construct the wedge on the traveled way side and the width may be reduced to 12" (305 mm) minimum with new concrete pavement, place it directly on the base material. Construct the concrete slab against the barrier. Rebar is to be placed on top of existing concrete pavement and doweled as shown in **DOWELING DETAILS** on Sheet 2. When compacted soil on the opposite side must be placed against the barrier of a minimum height of 3" (75 mm).

SEALING JOINTS: Use a butt longitudinal joint between the barrier and adjoining concrete pavement sealed with CMS 705.04 Joint Sealer. See **DOWELING DETAILS** on Sheet 2.

TRANSITIONS: Make these transitions between different types of barrier with 20' (6.1 m) length.

END ANCHORAGE: Reinforcing End Anchorage are required at the ends of another barrier run, construct the last 15' (4.5 m) using the END ANCHORAGE. Reinforcing End Anchorage are required at the ends of another barrier run, construct the last 15' (4.5 m) using the END ANCHORAGE. Reinforcing End Anchorage are required at the ends of another barrier run, construct the last 15' (4.5 m) using the END ANCHORAGE.

STATION MARKINGS: Impress markings in the "green" concrete on both sides of the top of the barrier. The cost is incidental to the unit cost bid for this barrier.

RACEWAY: Locate as shown on **RACEWAY PLACEMENT** Detail, unless otherwise noted. The cost of the 4" (100 mm) polyvinyl chloride raceway is included where shown on the plans. The cost for additional raceways and No. 10 AWG copper raceway installation is also included where shown on the plans for future installation of circuits.

PAYMENT will be made at the unit price bid per Foot (Meter) for **Item 622 - Concrete Barrier, Single Slope, Type**. Payment will be made at the unit price bid per Foot (Meter) for **Item 622 - Concrete Barrier, Single Slope, Type**. Payment will be made at the unit price bid per Foot (Meter) for **Item 622 - Concrete Barrier, Single Slope, Type**. Payment will be made at the unit price bid per Foot (Meter) for **Item 622 - Concrete Barrier, Single Slope, Type**.

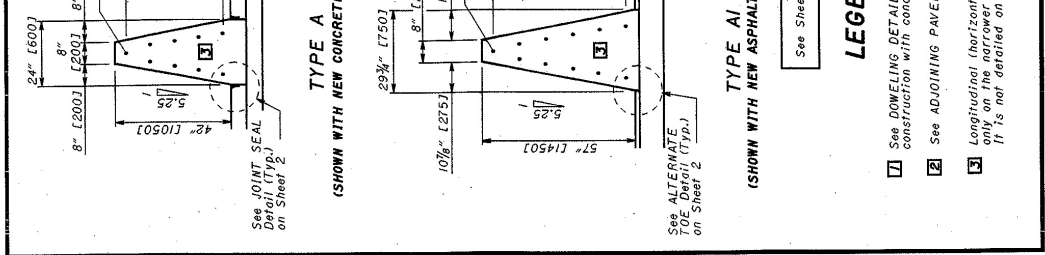
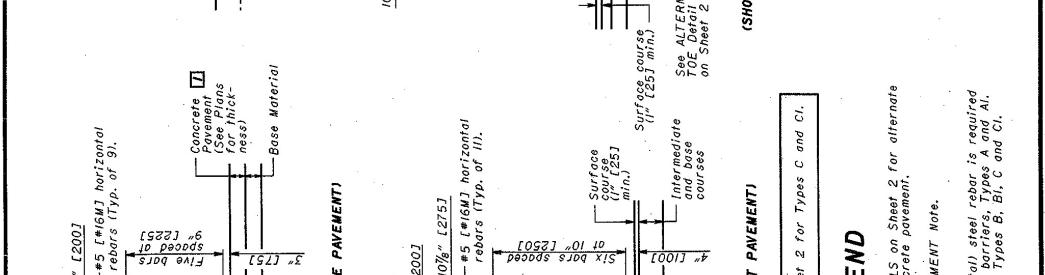
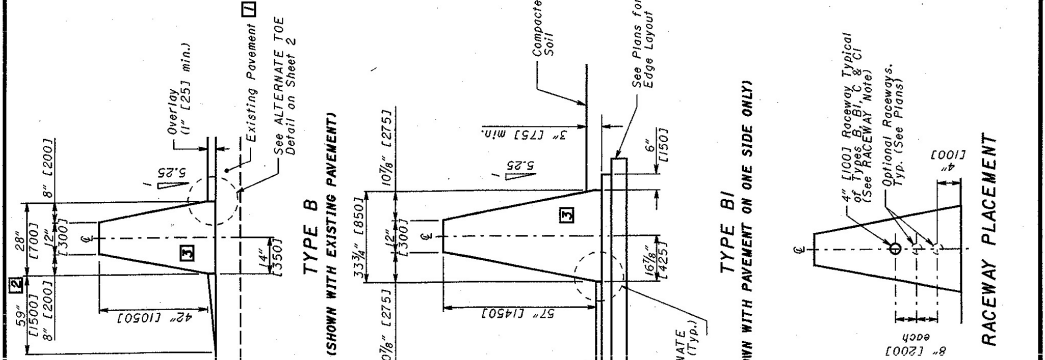
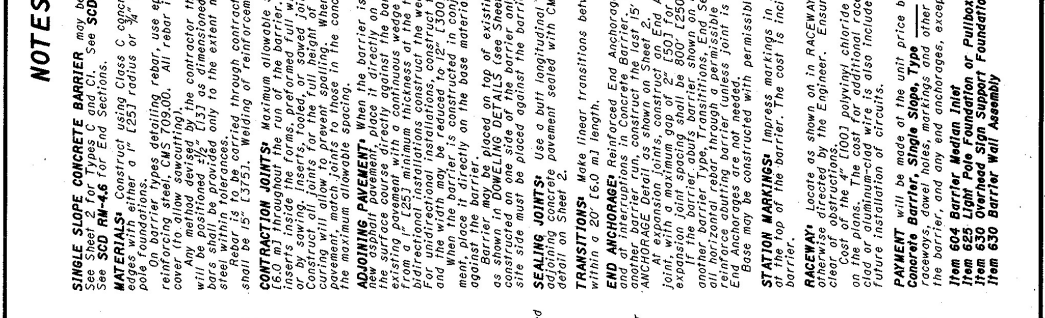

LEGEND

1 See **DOWELING DETAILS** on Sheet 2 for alternate construction with concrete pavement.

2 See **ADJOINING PAVEMENT** Note.

3 Longitudinal (horizontal) steel rebar is required only on the narrower barriers, Types A and AI. It is not detailed on Types B, BI, C and CI.

Figure 12. rm-4.3_4-18-03.pdf

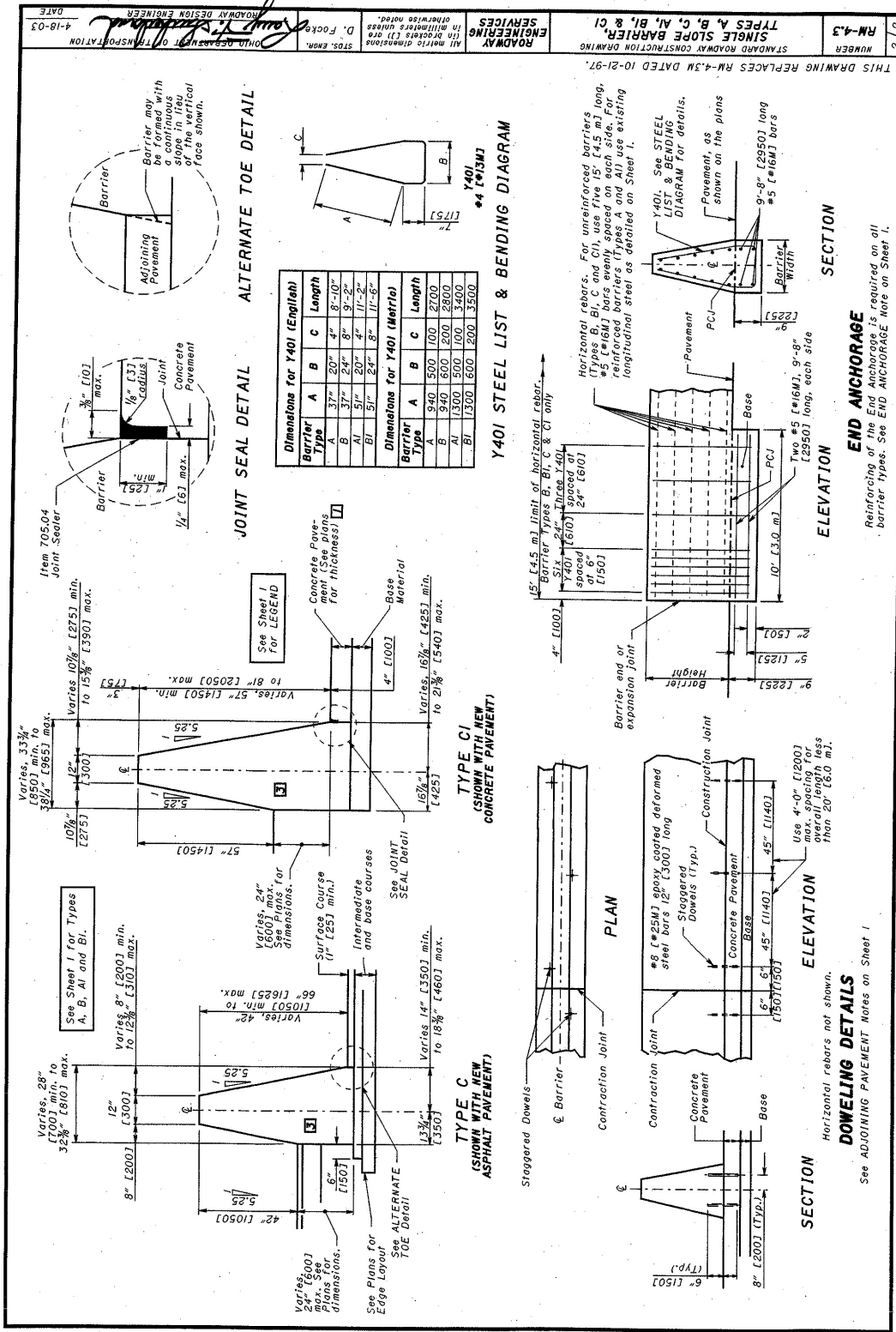

Figure 12. rm-4.3_4-18-03.pdf

MwRSF Response:

Michael:

Thanks for the email inquiry regarding single slope concrete barriers. I have briefly reviewed your three sets of CAD details and will try to answer your questions and provide additional comments. My remarks will be provided below in **RED**.

Ron

Ronald K. Faller, Ph.D., P.E.
Research Assistant Professor

Midwest Roadside Safety Facility (MwRSF)
University of Nebraska-Lincoln
527 Nebraska Hall
Lincoln, Nebraska 68588-0529

(402) 472-6864 (phone)

(402) 472-2022 (fax)

rfaller1@unl.edu

From: Michael.Bline@dot.state.oh.us [mailto:Michael.Bline@dot.state.oh.us]

Sent: Thursday, April 29, 2010 6:16 AM

To: rfaller1@unl.edu; rbielenberg2@unl.edu; dsicking@unl.edu; kpolivka2@unl.edu

Cc: Maria.Ruppe@dot.state.oh.us; Dirk.Gross@dot.state.oh.us

Subject: Single Slope Barrier Question

Hello all,

On page 2 of 2 in the pdf named rm43_jan07 there is a requirement to construct a reinforced end anchorages at all expansion joints. When the barrier wall abuts a inlet that requires a expansion joint on each end (I-2.1_jul05_v8.pdf) an end anchorage would be required on both sides. Our previous drawing rm-4.3_4-18-03.pdf did not require an reinforced end anchorage but the note on page 1 of 2 labeled End Anchorage required "all horizontal rebar through a permissible construction joint to continuously reinforce abutting barrier".

Expansion Joints

**** Per detail RM-4.3, January 2007, it is clearly and correctly stated that the reinforced concrete end foundation anchorages are required when an expansion joint or gap is to be placed within the single slope barrier system or when terminating the barrier at its end. When such barrier discontinuities are used in rigid barriers, the redirective capacity of the**

barrier can be greatly reduced due to its inability to form multiple yield lines throughout the section. As a result, a common practice has been to increase the size/quantity for the vertical and longitudinal steel reinforcement at the end sections as well as to increase the embedment depth of the concrete section, such as to integrate a grade beam or footing into the end section. At expansion joints, a narrow gap is often placed completely through the entire cross section, say 2 in. Per detail RM-4.3, April 2003, the OH DOT treated expansion joints in a similar manner to that now shown in the 2007 detail. However, the length of the embedded end anchorage has increased from 10 ft in 2003 to 15 ft in 2007, which is a reasonable modification.

Construction Joints

**** Per detail RM-4.3, April 2003, it is clearly and correctly stated that the end longitudinal steel reinforcement is to be carried across the construction joint in a continuous manner. This treatment is often handled by leaving exposed rebar segments of sufficient length out of the end of the cast-in-place or slip-formed barrier section. When the concrete construction is eventually continued, new longitudinal rebar are tied to the exposed bars and covered with concrete. Full continuity is provided at these locations when sufficient lap length is provided to ensure moment transfer across construction joint locations.**

**** In the OH DOT 2007 detail RM-4.3, it appears as though the longitudinal bars are now ended within the first concrete pour, and then 3/4-in. diameter by 18" long dowel bars are used to connect the two abutting vertical surfaces to one another. In this configuration, less than 9" of bar overlap would occur. It also may be difficult to place the dowel bars reasonable close to the existing bars and ensure continuity. The required overlap to ensure moment continuity would certainly exceed 9". If full moment continuity is expected across the construction joint, then it would be recommended to extend the longitudinal reinforcement of appropriate length through the joint. Then, the new longitudinal steel would splice to the exposed steel when the concrete placement operations were continued. If the dowel joint detail is still desired, it would be necessary to ensure that moment continuity and adequate bar development is provided across the joint.**

Do you have any information or testing on why this change would have been made?

**** Unfortunately, I do not recall any prior discussions with Dean Focke, OH DOT regarding the change in details for the construction joints between 2003 to 2007. In addition, I am unaware of any test results regarding this issue. I went back to look at the original CALTRANS CAD details for the Type 60 family of barriers. When construction joints were shown, the footnote stated "Reinforcing steel shall extend continuous through construction joints." In addition, we assume full barrier capacity through construction joints since the steel is continuous (i.e., adequately lapped and developed) and concrete fills the gap. As such, no end anchorages and footings are needed at these construction joint locations.**

If 57" single slope barrier wall is being constructed with no rebar or foundation and abutting reinforced inlet with foundation separated with a .75" expansion joint; what would be your opinions on performance, TL, snagging potential, etc. This barrier is TL-5 along a continuous run but what would be the rating if ending the barrier run with no foundation or rebar?

**** I am not a proponent for non-reinforced concrete barriers even though the Ontario tall wall previously demonstrated the ability to meet TL-5 when placed within a shallow asphalt concrete pad on the front and back sides. Non-reinforced barriers would likely crack over time, even to the point where visual gaps would exist throughout the cross section. In this scenario, no rail continuity would exist, and vehicle redirection would be a dependant on a combination of several factors, including the inertial resistance of the thick concrete barrier, any bond between the barrier and support surface, and the limited structural capacity of the concrete cross section (shear, tension, torsion, bending, etc.) away from the gap location. It would be helpful to review a rough sketch or CAD detail for the configuration noted above as I am having difficulty picturing this scenario. Would it be possible to obtain such a sketch?**

Ron

Problem # 24 – Steel Bridge Railing Question

State Question:

Ron,

What would be your opinion of installing a steel bridge railing (Illinois 2399 curb-mount) at standard post spacing (6'-3" as tested), but increasing the post spacing at four locations on the bridge in order to accommodate some structural members? Our consultant feels they can limit the maximum post spacing at these locations to 7'-6". Do you think allowing the larger post spacing at these locations would be feasible without additional testing, or should we be investigating other options?

There would be only 1 spacing of 7'-6" at each of the four locations on the bridge.

Thanks for your input.

Chris Poole, P.E.
Litigation/Roadside Safety Engineer
Office of Design
Iowa Department of Transportation

MwRSF Response:

Chris,

MwRSF feels that increasing the post spacing from 6'-3" to 7'-6" in only a few non-adjacent spans is a possible task. However, the bridge rail must be stronger to accommodate the 20% increase in moment due to the elongated post spacing. As such, we recommend the following:

Replace the 4"x4" bottom tube with another 8"x4" tube (the top tube). Thus, the bridge rail would consist of 2 8"x4" tubes. Assuming the top and bottom rail carry equal loads (which it really doesn't – top takes more load), this small change would provide a 30% increase in rail strength - enough to accommodate the 20% increase in moment.

This rail combination should be used throughout the bridge to ensure rail continuity and prevent snag points

Also, keep the bottom of the lower tube at 14" above the roadway. Thus the top of the lower tube is 22" above the roadway (2" gap between rails). This will allow the lower rail to better interact with an impacting vehicle and absorb more of the impact load.

Hopefully this helps your situation.

Scott Rosenbaugh

Problem # 25 – Steel Bridge Railing Question – Part II

State Question:

Thank you for looking into the rail issue.

We have an additional question to follow up the attached email which recommended that an 8" x 4" tube be used on the bottom rail throughout the bridge.

Since this bridge is relatively long, using an 8" x 4" tube for the bottom rail over the entire length would result in a significant increase in the steel quantity and cost. (The length of bridge to receive new rail is about 3,000 feet and the weight difference between a 8 x 4 x 5/16 tube and a 4 x 4 x 1/4 tube is 11.14 pounds per foot. Thus there would be an increase in steel of about 2 x 3,000 feet x 11.14 lb./ft. = 66,840 pounds.) Also, we would like to minimize the additional total dead load that is added to the bridge since the weight capacity of the bridge is an issue. (We are even planning to use lightweight concrete for the curbs on this project.)

In view of this, would it be possible to strengthen the rail at only the few areas where the span would exceed 6' 3"? In order to accomplish this, could the rail be strengthened at just those longer rail spans and any necessary adjacent spans, while using a 4 x 4 x 1/4 tube for the bottom rail throughout the rest of the bridge? The following are some ideas for your consideration to accomplish this:

- Increase the wall thickness of the standard top and bottom rails in order to get a 20 % or greater increase in the section modulus (S) for bending. This would result in no change in the outside railing geometry.
- Install a tubular member inside of the standard top and bottom rails in order to get a 20 % or greater increase in the section modulus for bending. For example, a 4 x 4 x 1/4 tube has a S of 3.90 inches³. If a 3 x 3 x 3/16 tube (S = 1.64 inches³) were inserted inside of the 4 x 4 tube, the total S for the bottom rail would be increased by 42 %. This would result in no change in the outside railing geometry.
- Add another 4 x 4 x 1/4 tube directly above the standard 4 x 4 x 1/4 bottom rail to increase the bending strength. In order to avoid a snag point, this section would need special fabrication at the ends for a transition down to the typical bottom rail.
- Replace the bottom rail with a 8 x 4 x 5/16 tube as recommended in the attached email, except fabricate a special transition down to a 4 x 4 x 1/4 tube at the ends in order to avoid a snag point.

Please let us know if any of the above concepts would be acceptable, and if so, we will ask the consultant to investigate further.

Thank you.

Chris Poole, P.E.
 Litigation/Roadside Safety Engineer
 Office of Design
 Iowa Department of Transportation

MwRSF Response:

Chris,

We do feel that we can strengthen the rail in the areas surrounding the extended post spacing only. With a 3,000 ft bridge, using the increased rail size for the entire system would be wasteful. Comments on the proposed solutions are discussed below.

(1). Using a thicker / stronger rail in certain areas will result in abrupt stiffness transition points at the connections between the two rail types. These stiffness transitions could lead to vehicle instabilities or snagging.

(3) & (4) Altering the shape of the rail in these locations can lead to more vehicle interaction problems (snagging, instabilities, wedging, etc...). As such, we do not favor the option of transitioning between different rail geometries without testing these transitions.

(2) MwRSF does like the tube-in-a-tube idea for strengthening the rail. The inserted tube should fit relatively snug inside the original tubes, so that the smaller tube develops load before the rail suffers larger deformations. The 3x3 tube inside of the lower rail (4x4x1/4) tube is a good fit. However the upper rail should also be reinforced. The same 3x3 tube could be used if its

position could be centered inside the 8x4 (perhaps resting it between the attachment bolts, bolting through the 3x3 tube, or using spacers to position the 3x3 tube inside the 8x4 tube.

The inserted reinforcement tubes should be extended out from elongated spacing, though the adjacent spacing of 6'-3", and to the nearest ¼ spacing. The 1/4 points of the rail are recommended for the stiffness transition to prevent the tube end from occupying a point of maximum deflection / deformation (midspan) or a stress concentration point (at the posts). Thus, the inner tubes should be extended 94 inches past the posts of the longer spacing (6'-3" plus 19"). Total length of the inner tubes would then be 188 inches plus the length of the longer post spacing (approximately 7'-6" from your previous e-mail.

Hopefully this helps and I answered all the questions below. Let me know if you need anything else.

Scott Rosenbaugh

Problem # 26 – Steel Bridge Railing Question – Part III

State Question:

Hi Scott,

I've got one more (hopefully the last) request for you regarding our I-74 bridge rail replacement. Apparently our consultant, rather than incorporating your previous advice, has developed an alternate method for spanning the wide expansion joints on the I-74 bridge. This method places specially-designed posts on either side of the joint, spaced 5 feet apart.

Could you please review and comment on the attached drawings showing the proposed design? Just as before, this will be used at a total of four locations on the bridge - on both sides of the road at each of the two suspension towers.

The post spacing varies in order to avoid the vertical stringers located just beyond the edges of the bridge deck.

The consultant felt that he needed to space the corbels (and therefore the posts) in order to avoid the vertical trusses due to the tight tolerances (see the attached picture of the current bridge). The vertical trusses are located approximately 1'-5" behind the face of rail. Would you agree that even if a post were placed at a truss location, that the truss would lie outside the working width of the barrier?

The proposed spacings have not been analyzed. Do you feel the abrupt changes in post spacing throughout the bridge is concerning enough to warrant a possible redesign? If we could

somehow reduce the depth of the corbels, perhaps that would allow them to be installed at truss locations?

Let me know if there's anything else you might need, and thanks again for your help.

-Chris

Chris Poole, P.E.
Litigation/Roadside Safety Engineer
Office of Design
Iowa Department of Transportation

MwRSF Response:

Chris,

The full scale testing on the original Illinois steel tube bridge shows a maximum dynamic deflection less than 3 inches. Also, although the working width of the system was not specified in the summary pages, the vehicle does not appear to extend more than 12 inches past the face of the rail. Thus, the 1'-15" of clear space between the face of rail and the vertical trusses provides enough room to minimize the risk of vehicle snag on the truss members. Further, the 17 inches of space matches that of the recommended offset from the head ejection envelope developed in TRP-03-194-07 for the 95th percentile passenger (14 in. + 3 in. = 17 in.).

With a maximum dynamic rail deflection < 3" with the post spacing at a constant 6'-3", I am not concerned about pocketing of this rail when the spacings you have shown are all between 5'-6" and 3'-6". All the extra posts will only stiffen the bridge rail. Therefore, the post spacings you show are acceptable and the splice at the tower locations should work.

Scott Rosenbaugh
Midwest Roadside Safety Facility (MwRSF)
University of Nebraska – Lincoln

Problem # 27 – ZOI

State Question:

Hello Ron.

I have a question for you about ZOI research that you guys did several years ago.

On the summary diagrams for TL-3 barriers, you show a 24" lateral distance for vertical and only 18" for a safety shape. Why is the safety shape less? I would have thought a 32" vertical would have been less.

Thanks for any help that you can provide me.

Rod

MwRSF Response:

Rod:

For permanent, sloped-face, concrete barriers, the front-impact-side wheel will begin to climb the barrier face and both result in both vertical rise and roll away from the barrier. For most vertical-face barriers, the engine hood and crushed quarter panel will have a maximum lateral extent over the parapet due to reduced vehicle climb as compared to sloped-face barriers.

Ron

Ronald K. Faller, Ph.D., P.E.
Research Assistant Professor

Problem # 28 – Vertical Barrier

State Question:

Do you have some details of a 32” vertical barrier with thrie beam attachments? I appreciate it...

Thanks,

Scott King
KsDOT

MwRSF Response:

Scott,

I have attached a few items for you. MwRSF had previously taken a thrie beam to safety shape transition and converted it to a vertical shaped wall. The design was submitted to FWHA for acceptance - both the drawing and the acceptance letters are attached. Also, TTI conducted a test on a thrie beam to vertical wall transition. The Ohio DOT drawing and the acceptance letter are attached.

Scott Rosenbaugh
Midwest Roadside Safety Facility (MwRSF)
University of Nebraska – Lincoln

Problem # 29 – MGS Approach Transition with Curbs

State Question:

We would like to install the MGS approach transition with a 6” curb in front of the transition.

What guidance can MwRSF give regarding this type of installation?

David L. Piper, P.E.
Acting Safety Implementation Engineer
Bureau of Safety Engineering

MwRSF Response:

Dave,

Installing 6” curb in front of the MGS and upstream of the transition will cause a curb to be present throughout the length of the guardrail system. This will put us in a gray area. The MGS was tested with a curb, and the bridge transition was tested with a curb, but the upstream transition (or transition to the transition) has not yet been evaluated with a curb.

Adding a curb to the transition can lead to a number of problems for both the small car and pickup truck vehicles. The 2270P vehicle will be subjected to a vertical force component on the impacting side as the tire rolls over a curb. This vertical force combined with the changing stiffness of the transition may lead to stability issues (namely vehicle roll) as the vehicle is redirected. These factors could lead to vehicle rollover – similar to that seen for the recent MGS test with 6” curb placed 8 ft behind the rail. With the curb placed much closer to the rail (within a foot) the vertical force has less time to create instabilities, but this may still cause problems since the rail stiffness in the transition area is not constant (post spacing reduces and rail becomes larger/stiffer as you move downstream).

For 1100C vehicle, the small car bumper has recently shown a propensity to extend under the 31” high rail and snag on the steel posts (demonstrated by both the recent transition test, MWTSP-3, and the MGS test placed on a Gabion Wall, MGSGW-2). During the mentioned tests, the vehicle was able to bend the posts over and continue downstream without violating the ORA or OIV values. However, with inclusion of a curb and additional soil fill behind it, the post becomes stiffer and the moment arm for post bending is reduced. Thus, bending the posts over as the vehicle impacts the system will take more force and energy. Further, as the tire rides up the curb the vehicle may become wedged between the curb and the bottom of the guardrail leading to further decelerations. The combination of these phenomena may lead to a violation of the ORA or OIV values (the transition test already saw a 14.7 longitudinal ORA and a 27.5 longitudinal OIV – recall maximum allowable values are 20.49 and 40, respectively).

After identifying these potentially critical mechanisms, MwRSF is hesitant to recommend the use of the upstream transition with a curb until further evaluation is conducted (most likely full-scale crash testing). However, I can point out a few design elements that would minimize the increased risk of adding a curb.

1. Extending the 4" triangular curb throughout the upstream transition would incorporate less of a vertical force to the vehicle than would a 6" high curb. Therefore, the 4" curb should be extended upstream at least 12.5 ft (2 full post spacings) past the first 37.5" or ½ post spacing. The transition to 6" curb can then be made over the next post spacing upstream of this point.
2. To mitigate some of the increased snag potential for the small car, it may be wise not to fill in the soil behind the 4" curb in the upstream transition area (specifically from the beginning of reduced post spacings to the first 6.5 ft long post. This would eliminate the extra force and energy required to bend the posts over if the vehicle bumper gets under the rail.

I hope this helps.

Scott Rosenbaugh
Midwest Roadside Safety Facility (MwRSF)
University of Nebraska - Lincoln