

*Guidelines for Designing Bridge Piers and Abutments for Vehicle Collisions*

**State Pooled Fund Study: TPF-5(106)  
Panel Meeting  
Phase 2**

April 14, 2009  
Texas Transportation Institute



---

---

---

---

---

---

---

---

*Phase 2 – Full Scale Crash Testing*

- Four Different Crash Testing Concepts
- Two Full Scale Crash Tests Possible for Phase 2



---

---

---

---

---

---

---

---

*Concept 1 – Single 30-Inch Diameter Pier*

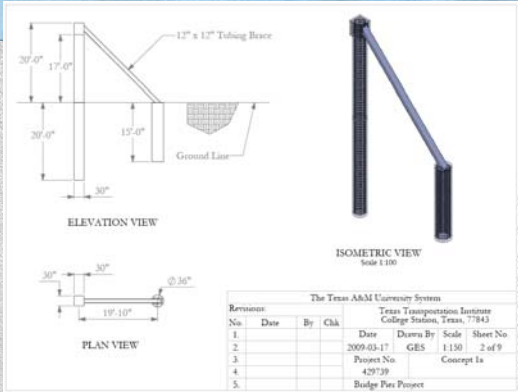

---

---

---

---

---

---

---

---

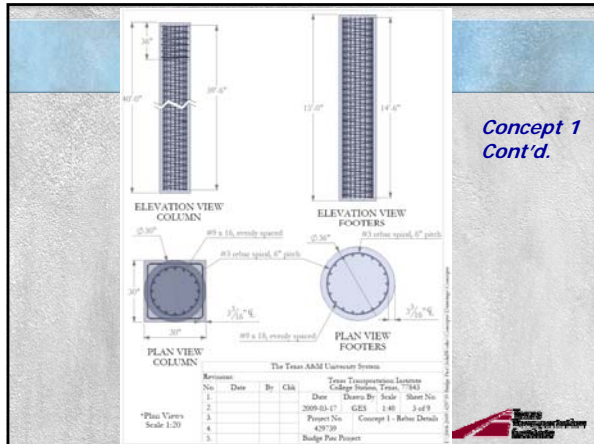

---

---

---

---

---

---

---

---

---

---

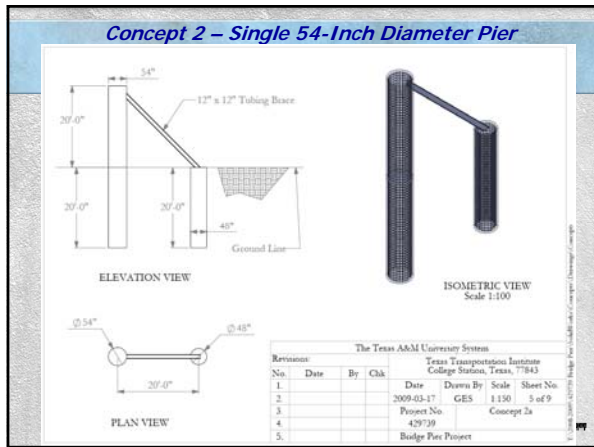

---

---

---

---

---

---

---

---

---

---

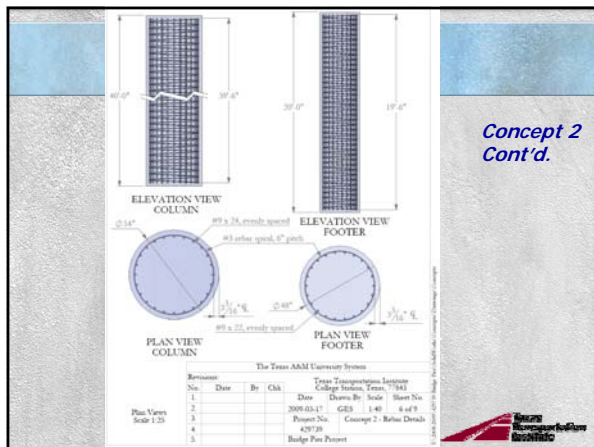

---

---

---

---

---

---

---

---

---

---

**Concept 3 – Two 30-Inch Dia. Piers with Retrofit**

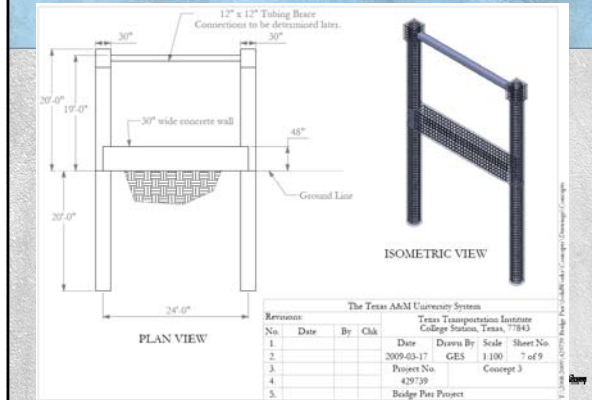

**Concept 3 Cont'd.**

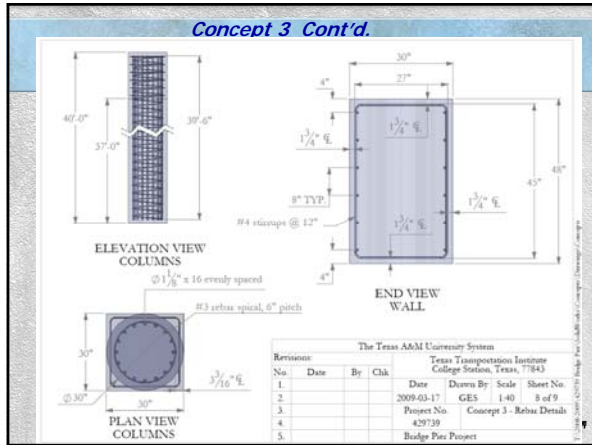

**Concept 4 – Instrumented Pier**

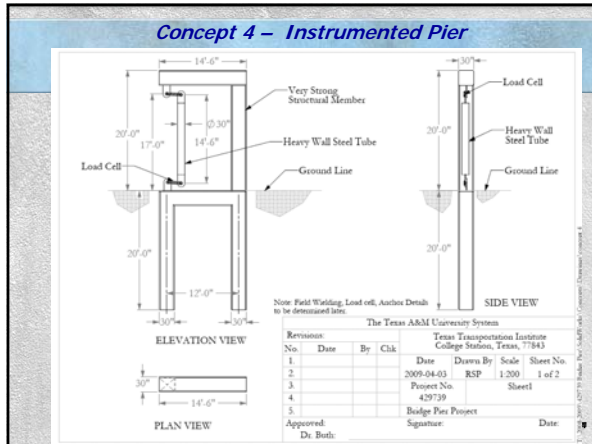

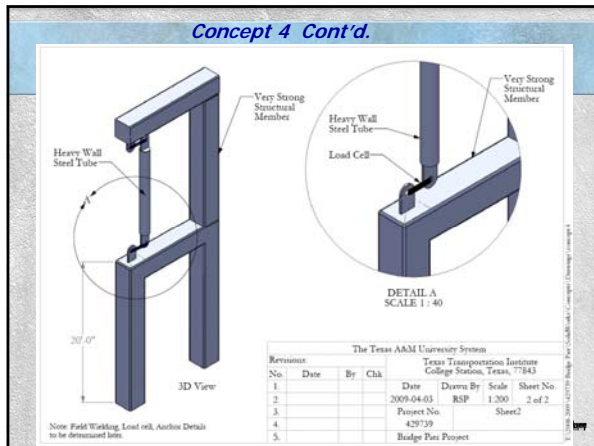

---

---

---

---

---

---

---

---

---

---

Phase 2 – Full-Scale Crash  
Testing Concepts ... Questions?



---

---

---

---

---

---

---

---

---

---